

PRODUCT SERVICE SCHEMATIC MANUAL

© Wang Laboratories, Inc., 1974

This manual contains company proprietary information.
Reproduction of this document in whole or in part
without the authorized consent of Wang Laboratories,
Inc. is prohibited.

INTRODUCTION

This manual contains schematic drawings and cable diagrams of the following products:

Model 100 System
Model 400 System
Model 500/520/600 Calculators
Model 700/720 Calculators
Model 1200 System
Model 2200 System
Peripherals of 500/520/600/700/720/2200
DIABLO Series 40 Disk Drive

The schematics are arranged in sections in the order listed above. A colored title and table of contents sheet begins each section. The schematics in each section are arranged in ascending numerical order by printed circuit board number disregarding F and L prefixes. Pertinent power supply schematics and cable diagrams are placed at the end of each section. Due to the unavailability at time of publication, some schematics and cable diagrams are missing, especially on newer products. Rough engineering drawings and preliminary drawings are not usually incorporated in this manual.

This manual will periodically be updated to include drawings and schematics of newly manufactured products, and drawings that are now sketches or not finalized.

The Model 300 series drawings are not included in this manual because of a prior publication *Series 300 Drawings* (03-0007-0) which incorporated all 300 schematic diagrams. All copies of this manual are exhausted and there are currently no plans to reprint due to expense and low priority.

Publication of this new schematic manual eliminates schematic diagrams from future Service Bulletins; bulletins will have assembly drawings only if available at time of publication.

In order to improve this publication, use the business reply form on the next page to send suggestions or requests for drawings which may have been omitted; these will be incorporated in the next update.

MODEL 100 SYSTEM

The following schematics are contained in this section in the following order:

TITLE	DRAWING #	NO. OF SHEETS
5950	C5950	2
5951	C5951	2
5952	C5952	2
5953	D5953	1
5954	D5954	1
5977	C5977	1
5979	D5979	1
5980	C5980	1
5985	C5985	1
6078	C6078	1
6079	C6079	1
6095	C6095	12
6105	C6105	2
6115	C6115-1	2
6115 Cable	C6115-2	1

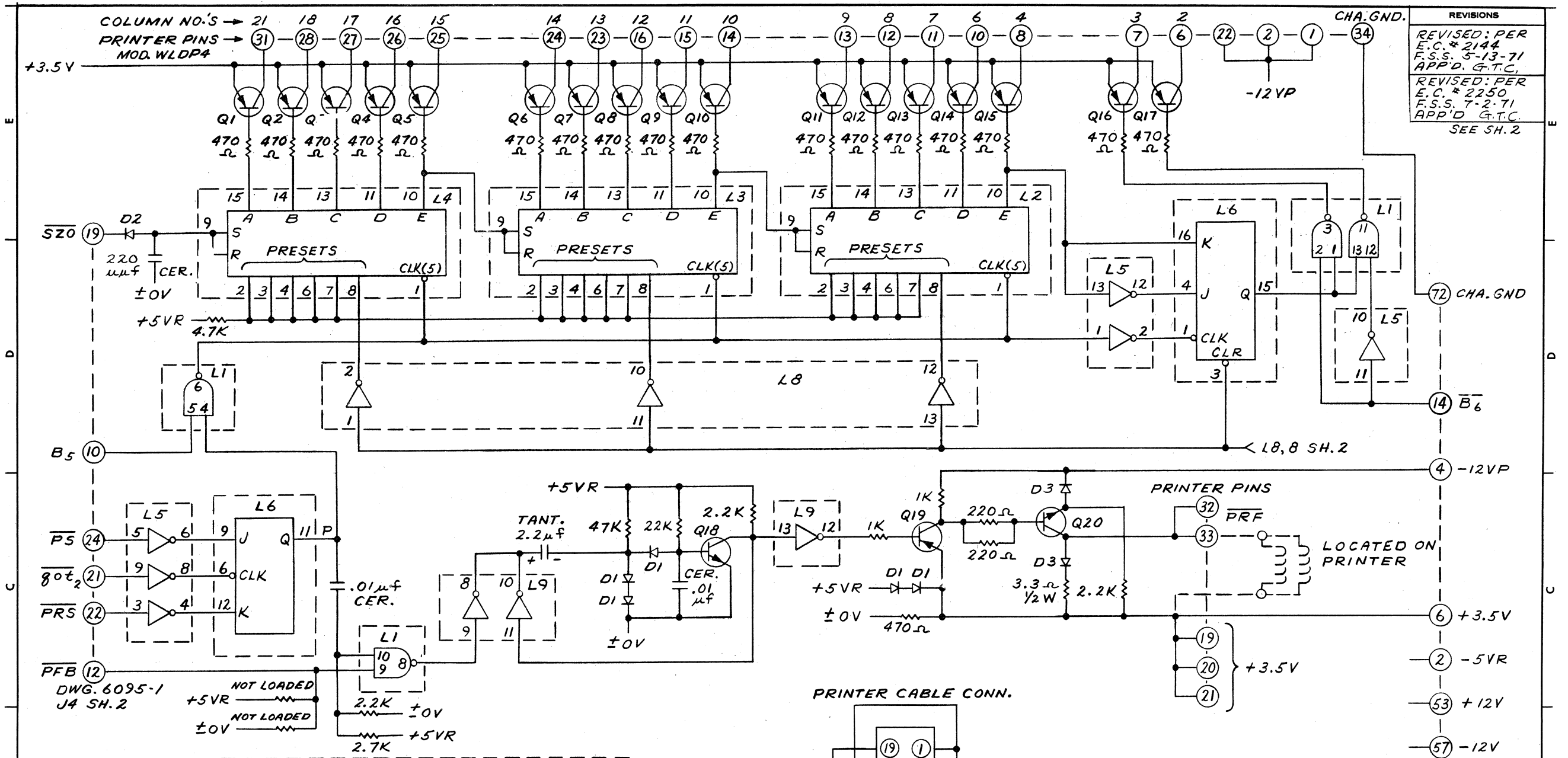

REVISIONS
 REVISED: PER E.C. # 2144 F.S.S. 5-13-71 APP'D. G.T.C.
 REVISED: PER E.C. # 2250 F.S.S. 7-2-71 APP'D. G.T.C.
 SEE SH. 2

DWG. 6095-1
 J4 SH. 2

NOT LOADED
 +5VR
 NOT LOADED
 ±0V

PRINTER CABLE CONN.

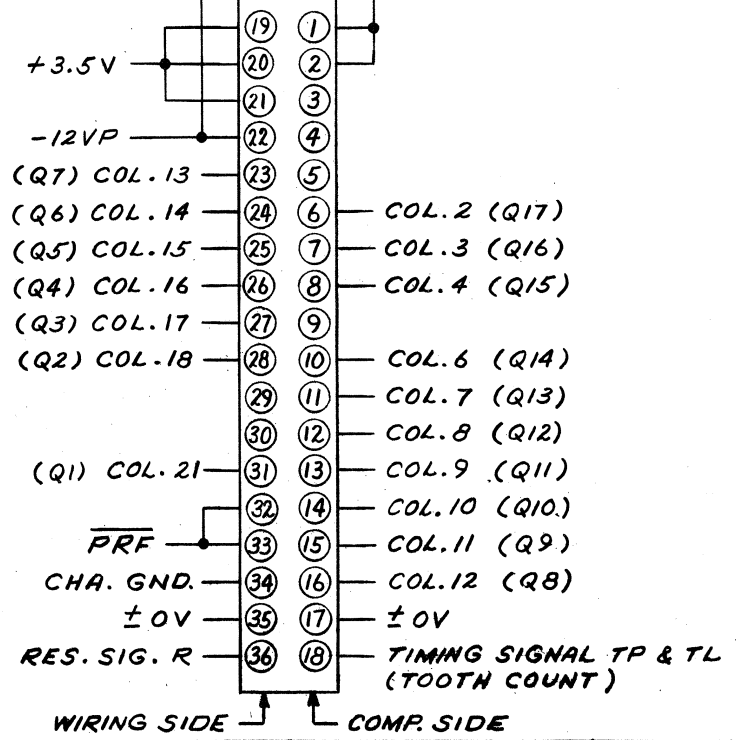

JUMP ONLY
 5950-1 OR
 5951-1
 DWG. 6095-1
 J4 SH. 2

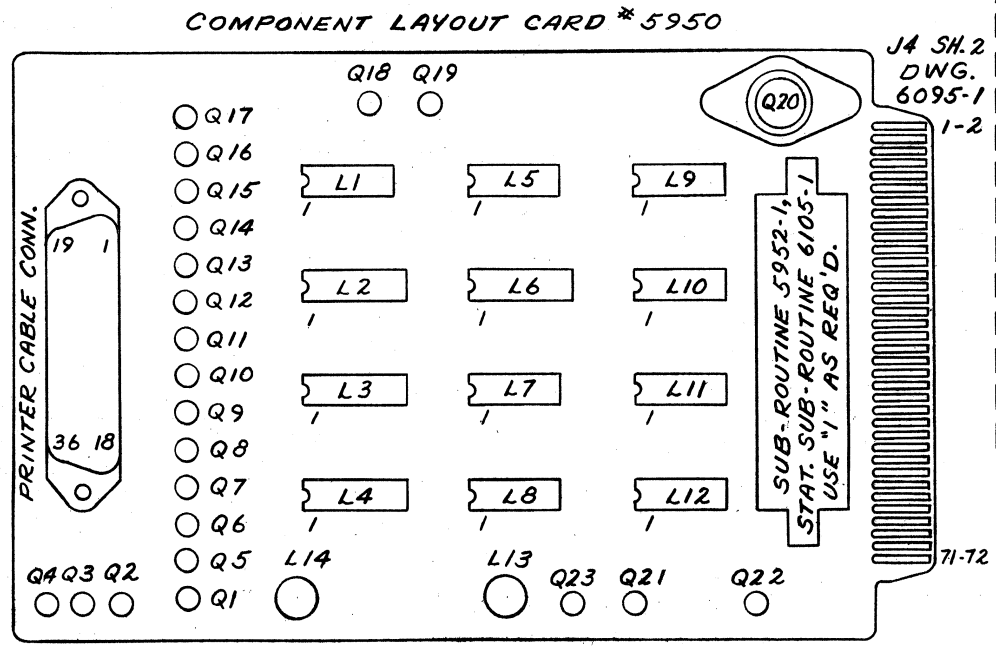

WANG LABORATORIES INC.
 TEWKSBURY, MASS.

MODEL NO.	DRAWN	F.S.S. 1/23/71	APP'D.	G.T.C. 3-31/71
100	CHECKED	RT 3-31-71	APP.	

TITLE
**SCHEMATIC LOGIBLOC * 5950-1
 PRINTER LOGIC**

W.O. NO.	DWG. NO.	REV.
	C 5950-1 SH1 OF 2	3

DWG. 6095-1

J4 SH.2

RESET (34) D2

REVISIONS
 REVISED: PER
 E.C. 2491 F.S.S.
 10-971 APPD GTC

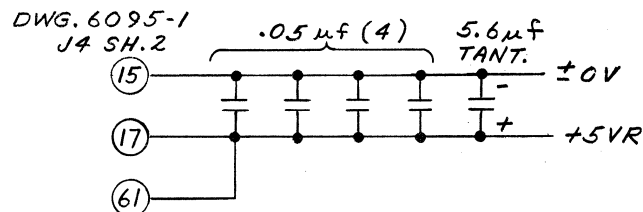
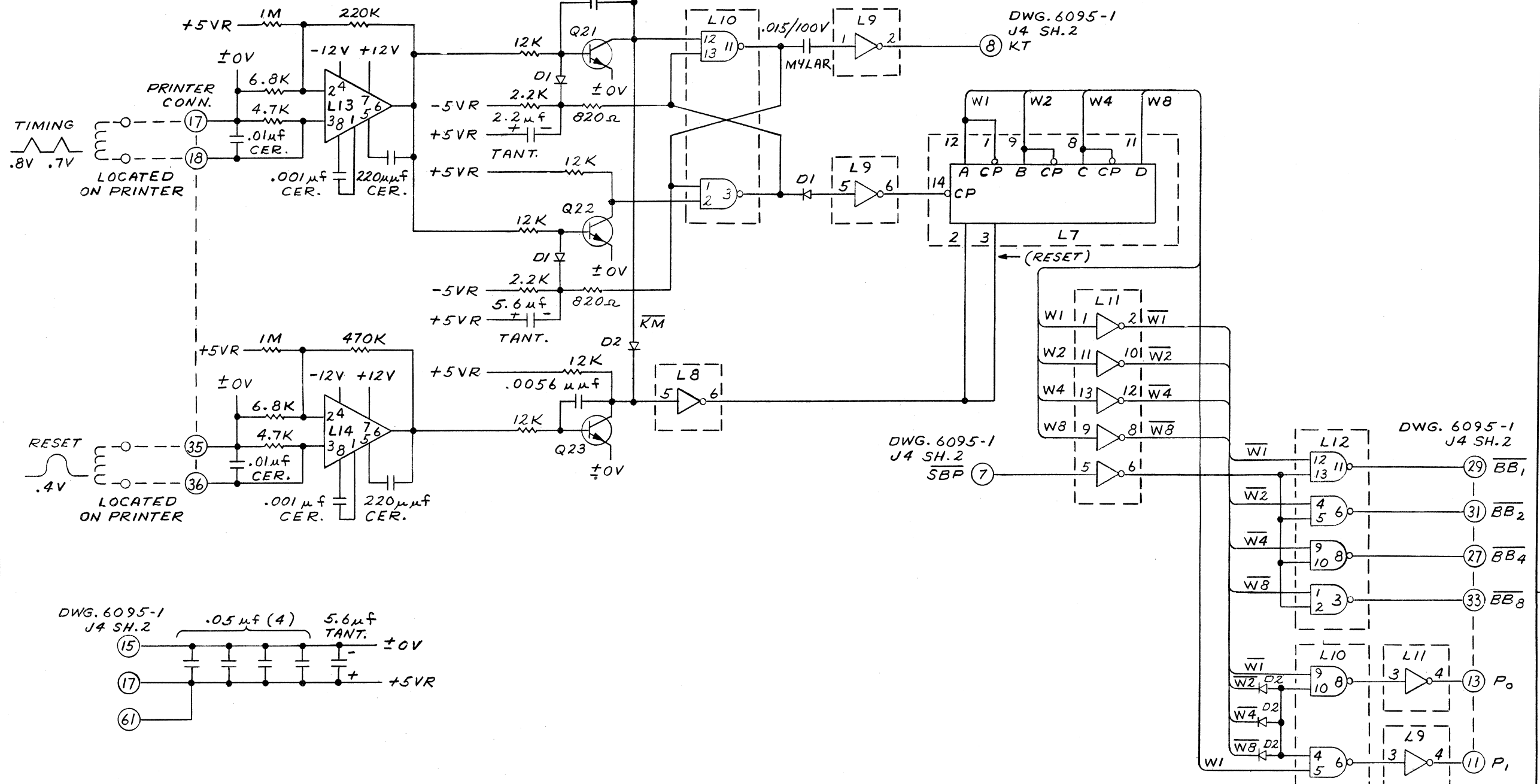

COMPONENT	TYPE	W.L. NO.	QTY.
Q1 THRU Q17,19	GT544	375-1017	18
Q18,21,22,23	CORE DR.SIL.	375-1005	4
Q20	40250	375-1022	1
D1	ADAM	380-1001	8
D2	GERM.	380-0000	6
D3	1N4719	380-3002	2

I.C. LOCATION	TYPE	W.L. NO.	TERM FOR VCC +5V	TERM FOR ±0V	QTY.
L13,14	709C	376-0000			2
L10	SN7400N	376-0002	14	7	1
L12	SN7403N	376-0028	14	7	1
L5,8,11	SN7404N	376-0010	14	7	3
L6	SN7476N	376-0007	5	13	1
L7	SN7493N	376-0011	5	10	1
L2,3,4	SN7496N	376-0065	5	12	3
L9	F9935	376-0025	14	7	1
L1	F9946	376-0023	14	7	1

NOTE:
 1. ALL RESISTORS 1/4 W UNLESS OTHERWISE SPECIFIED.
 2. SEE DWG. 5951-1 SH. 2 FOR CONNECTORS 5950, 5952, 6095 AND 6105

WANG LABORATORIES INC.
 TEWKSBURY, MASS.

MODEL NO. 100
 DRAWN F.S.S. 1-25-71
 CHECKED RT 3-31-71
 APP. GTC 3-31-71

TITLE SCHEMATIC LOGIBLOC #5950-1
 PRINTER LOGIC

W.O. NO. DWG. NO. C5950-1 SH2OF2 REV. 3

1-05650 ON 9MG

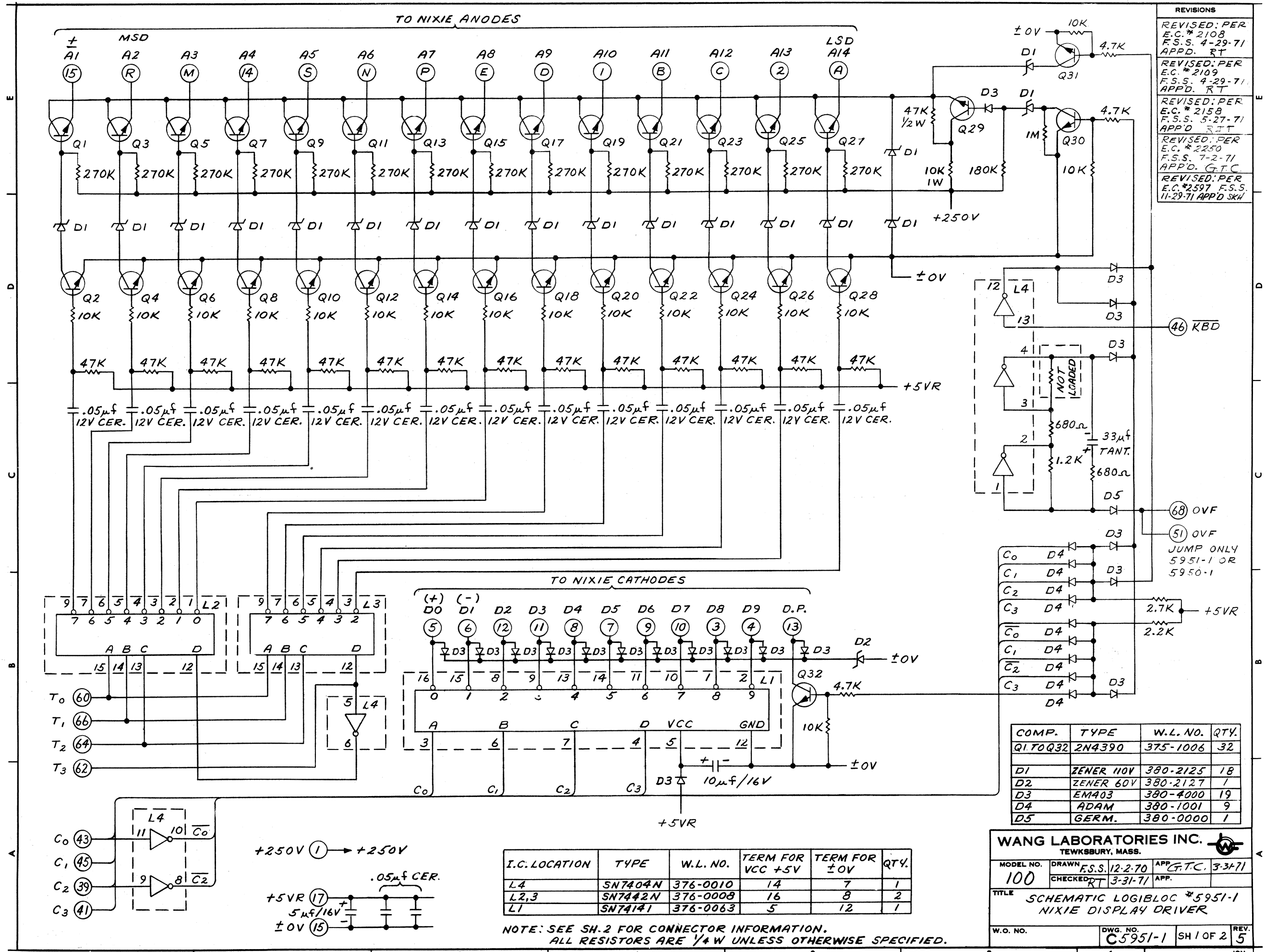

REVISIONS

REVISED: PER E.C. # 2108 F.S.S. 4-29-71 APPD. RT
REVISED: PER E.C. # 2109 F.S.S. 4-29-71 APPD. RT
REVISED: PER E.C. # 2158 F.S.S. 5-27-71 APPD. RT
REVISED: PER E.C. # 2250 F.S.S. 7-2-71 APPD. G.T.C.
REVISED: PER E.C. # 2597 F.S.S. 11-29-71 APPD. SKW

COMP.	TYPE	W.L. NO.	QTY.
Q1 TO Q32	2N4390	375-1006	32
D1	ZENER 110V	380-2125	18
D2	ZENER 60V	380-2127	1
D3	EMA03	380-4000	19
D4	ADAM	380-1001	9
D5	GERM.	380-0000	1

I.C. LOCATION	TYPE	W.L. NO.	TERM FOR VCC +5V	TERM FOR ±0V	QTY.
L4	SN7404N	376-0010	14	7	1
L2,3	SN7442N	376-0008	16	8	2
L1	SN74141	376-0063	5	12	1

NOTE: SEE SH.2 FOR CONNECTOR INFORMATION.
ALL RESISTORS ARE 1/4 W UNLESS OTHERWISE SPECIFIED.

WANG LABORATORIES INC.
TEWKSBURY, MASS.

MODEL NO. 100
DRAWN F.S.S. 12-2-70
CHECKED RT 3-31-71
APP. G.T.C. 3-31-71

TITLE SCHEMATIC LOGIBLOC #5951-1 NIXIE DISPLAY DRIVER

W.O. NO. C5951-1 SH 1 OF 2 REV. 5

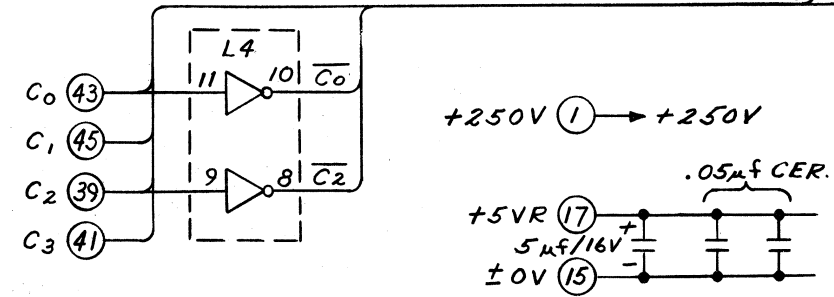

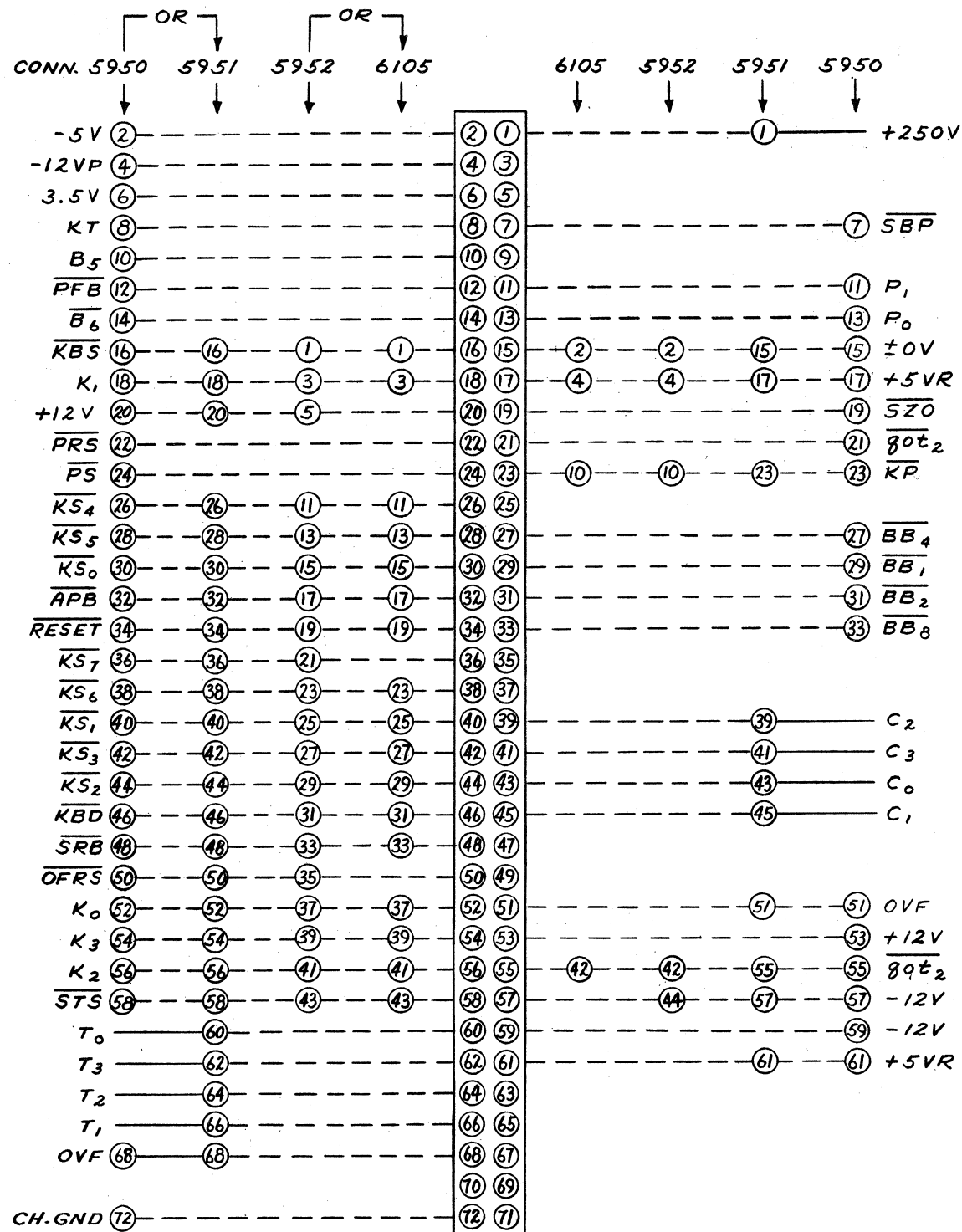
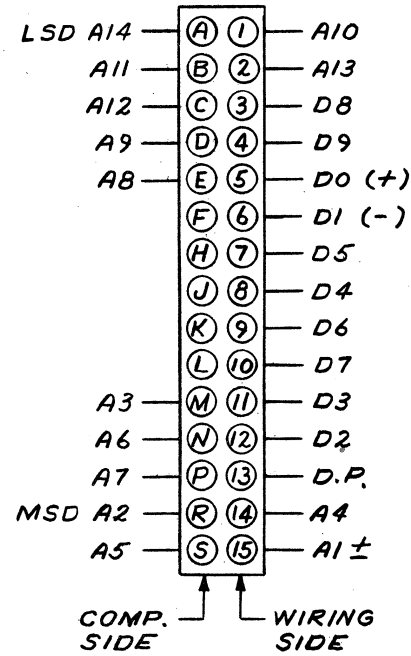
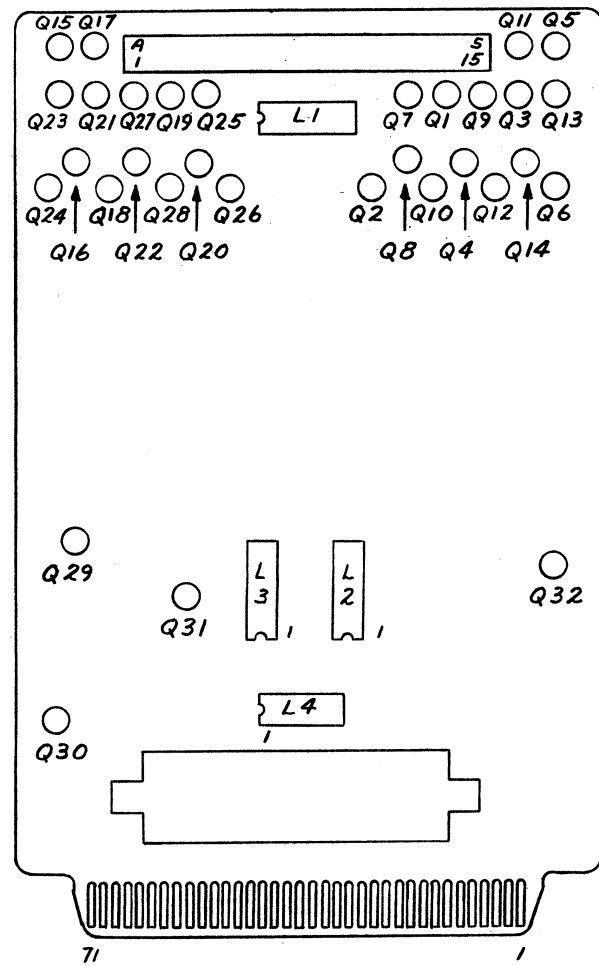

J4
SH. 2 OF 12
DWG. 6095-1

WANG LABORATORIES INC.			
TEWKSBURY, MASS.			
MODEL NO.	DRAWN	APP.	3/31/71
100	F.S.S. 3-10-71	G.T.C.	
CHECKED	RT	3-31-71	APP.
TITLE SCHEMATIC LOGIBLOC #5951-1 NIXIE DISPLAY DRIVER			
W.O. NO.	DWG. NO.	SH 2 OF 2	REV. 5
	C5951-1		

REVISIONS
 REVISED: PER
 E.C. #2273 F.S.S.
 7-20-71 APPD. G.T.C.

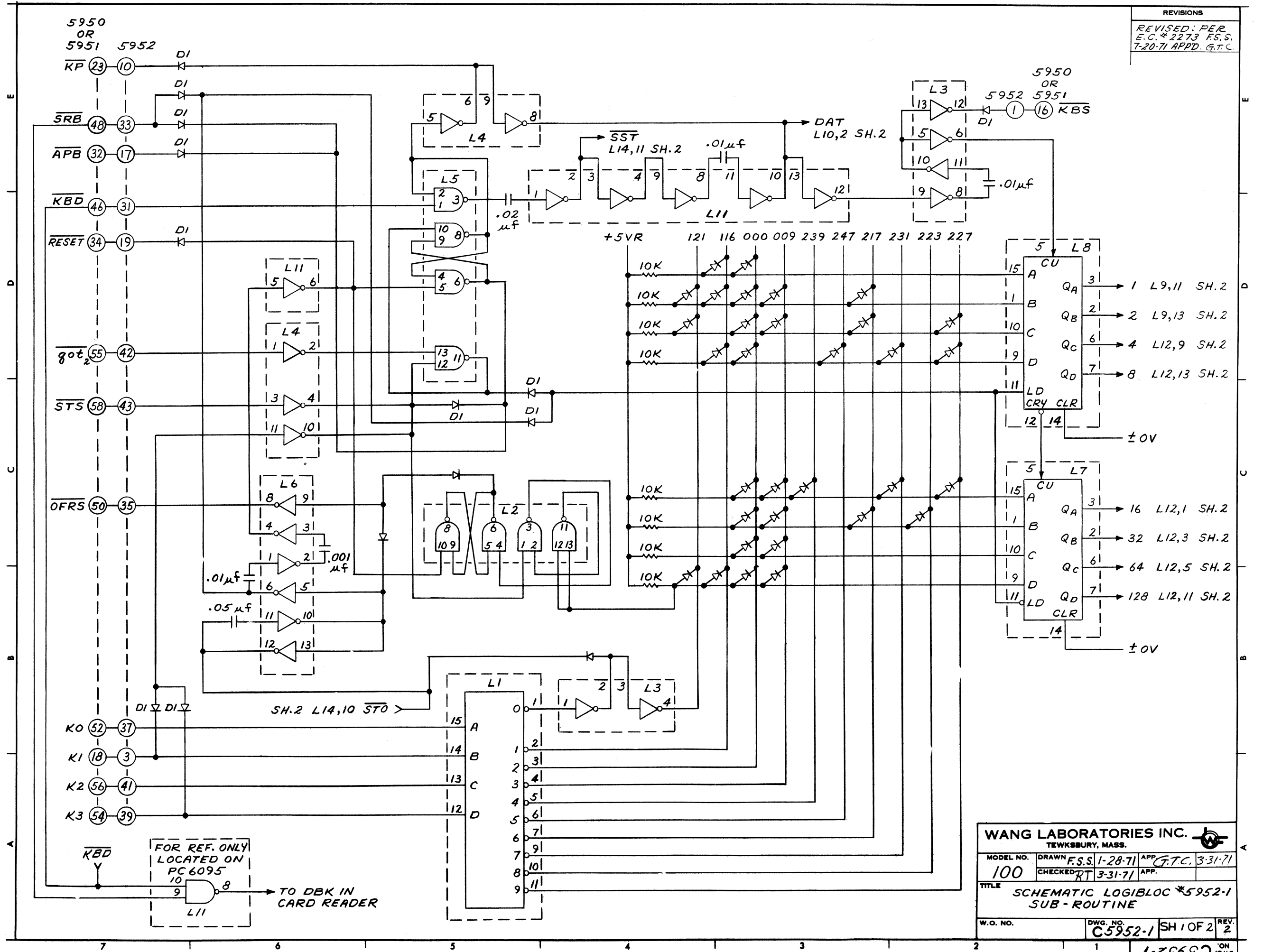

WANG LABORATORIES INC.
 TEWKSBURY, MASS.

MODEL NO.	DRAWN F.S.S. 1-28-71	APP. G.T.C. 3-31-71
100	CHECKED RT 3-31-71	APP.
TITLE SCHEMATIC LOGIBLOC #5952-1 SUB-ROUTINE		
W.O. NO.	DWG. NO. C5952-1 SH 1 OF 2	REV. 2

1-25690 ON 5952-1

REVISIONS
 REVISED PER
 E.C. 2367 F.S.S.
 8-26-71 APPD. GTC.

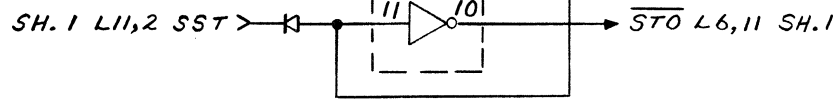
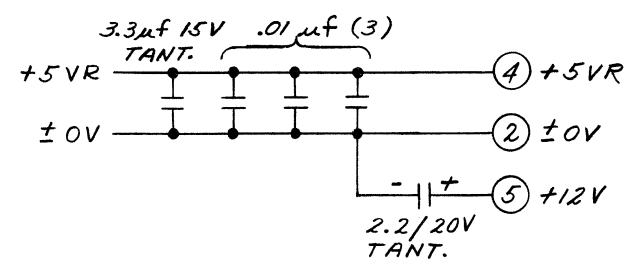
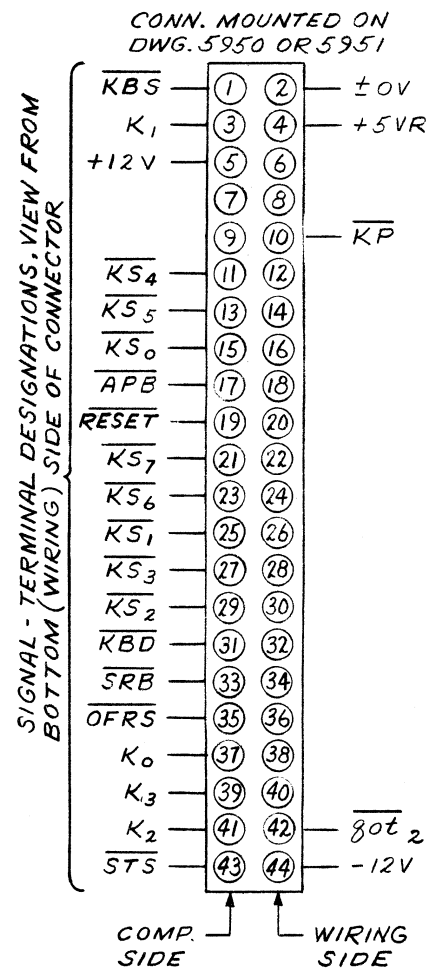
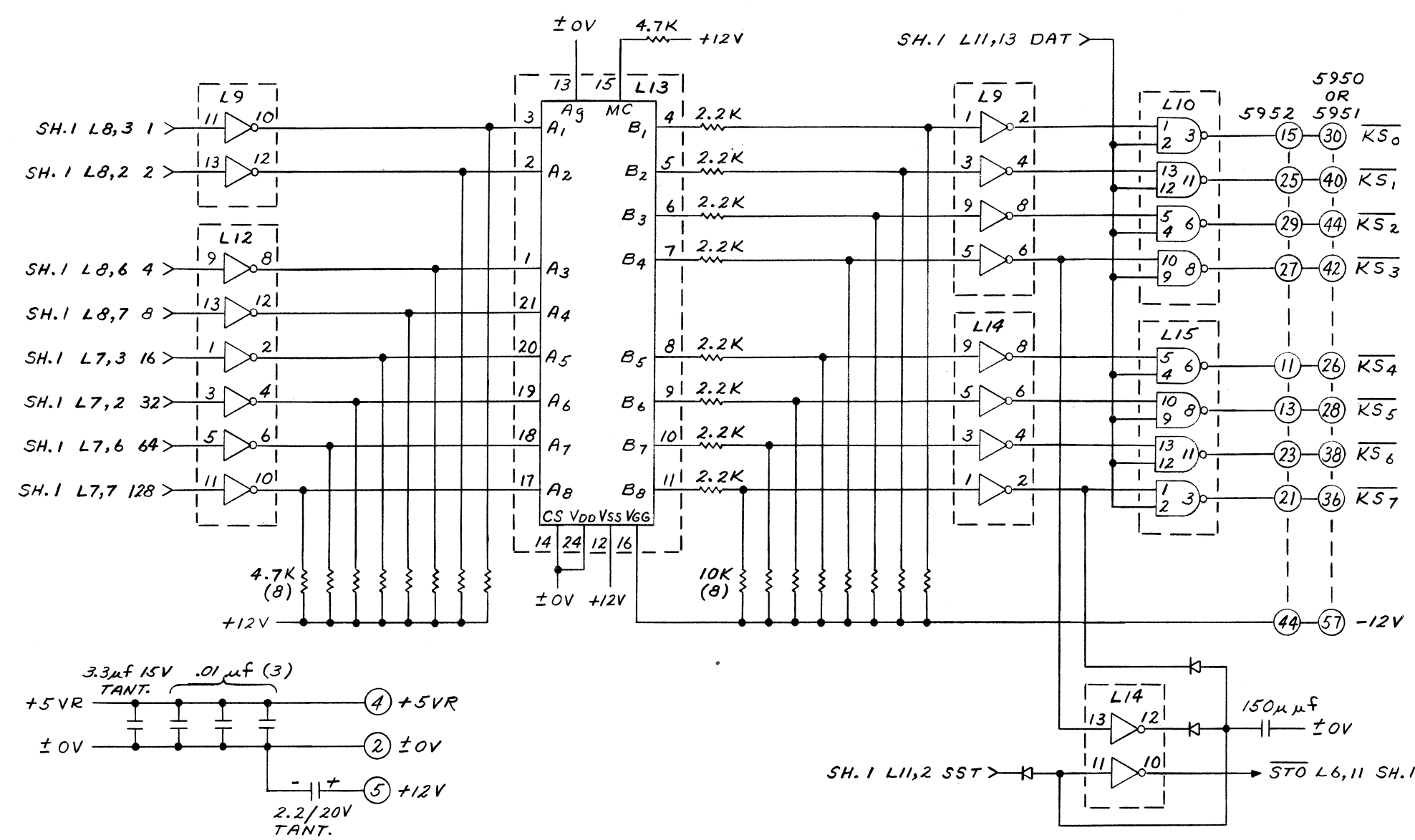

COMPONENT LAYOUT

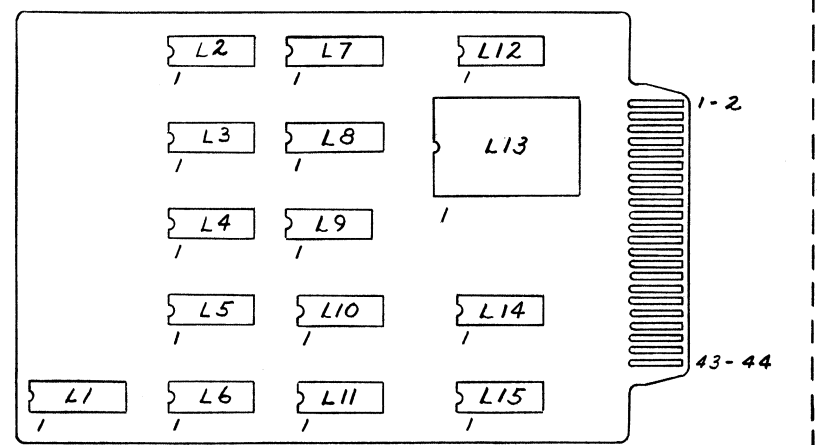

I.C. LOCATION	TYPE	W.L. NO.	TERM FOR VCC +5V	TERM FOR ±0V	QTY.
L2,5	SN7400N	376-0002	14	7	2
L10,15	SN7403N	376-0028	14	7	2
L9,12,14	SN7406N	376-0055	14	7	3
L1	SN7442N	376-0008	16	8	1
L3,4,6,11	F9935	376-0025	14	7	4
L7,8	74193	376-0053	16	8	2
L13	7425	377-0002			1

NOTE: DIODES "DI" ARE GERMANIUM, W.L. #380-0000 QTY. 11, ALL OTHERS ARE ADAM, W.L. #380-1001 QTY. 38. UNLESS OTHERWISE SPECIFIED ALL RESISTORS ARE 1/4W.

WANG LABORATORIES INC.
 TEWKSBURY, MASS.

MODEL NO. 100 DRAWN E.S.S. 11-25-70 APP. GTC. 3-31-71
 CHECKED R.T. 3-31-71 APP.

TITLE SCHEMATIC LOGIBLOC *5952-1 SUB-ROUTINE

W.O. NO. DWG. NO. C.5952-1 SH20F2 REV. 2

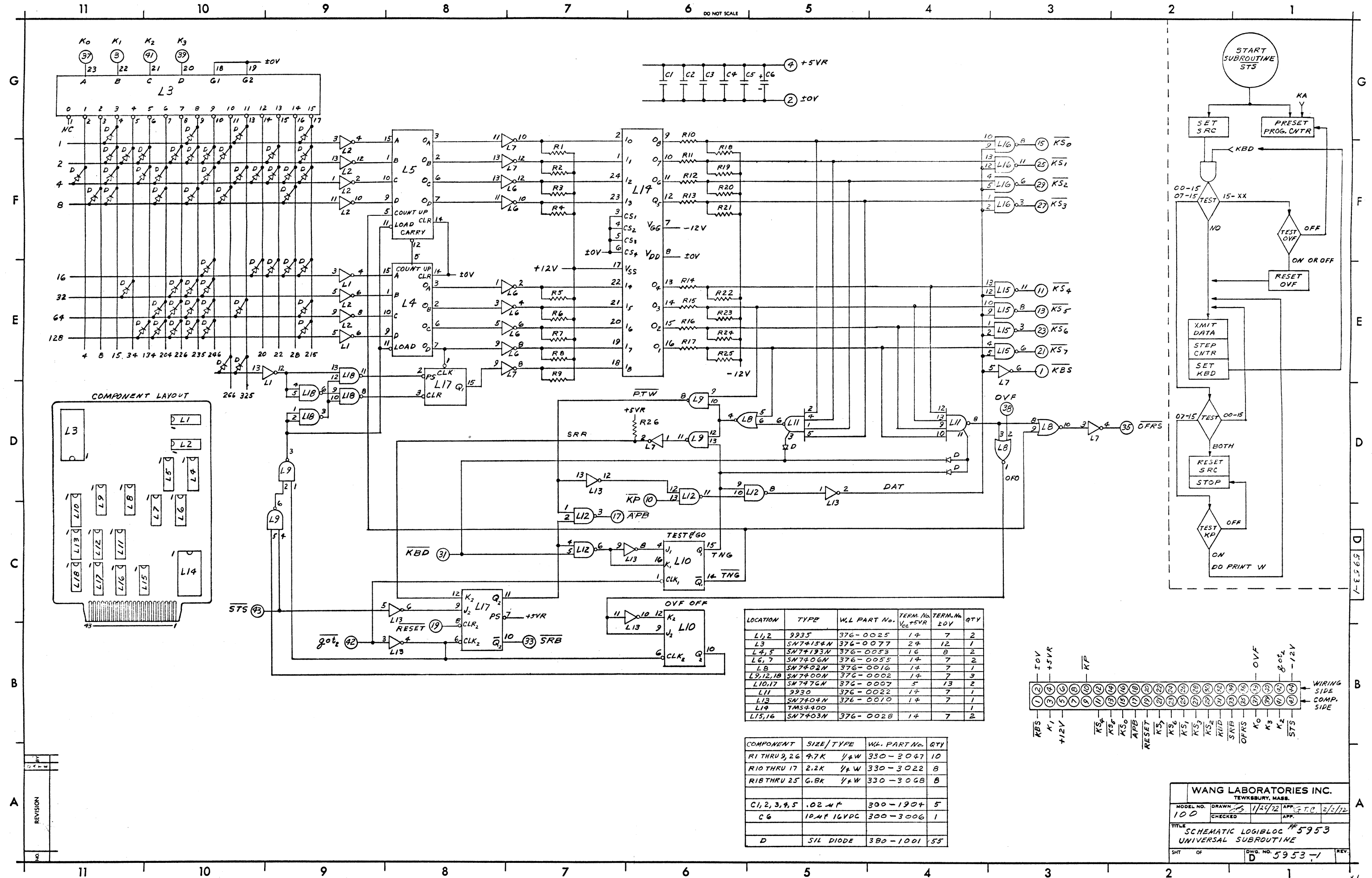

LOCATION	TYPE	W.L. PART No.	TERM. No. V _{CC} +5VR	TERM. No. ±0V	QTY
L1,2	9935	376-0025	14	7	2
L3	SN74154N	376-0077	24	12	1
L4,5	SN74193N	376-0053	16	8	2
L6,7	SN7406N	376-0055	14	7	2
LB	SN7402N	376-0016	14	7	1
L9,12,18	SN7400N	376-0002	14	7	3
L10,17	SN7476N	376-0007	5	13	2
L11	9930	376-0022	14	7	1
L13	SN7404N	376-0010	14	7	1
L19	TMS4400				1
L15,16	SN7403N	376-0028	14	7	2

COMPONENT	SIZE/TYPE	W.L. PART No.	QTY
R1 THRU 9,26	4.7K 1/4W	330-3047	10
R10 THRU 17	2.2K 1/4W	330-3022	8
R18 THRU 25	6.8K 1/4W	330-3068	8
C1,2,3,9,5	.02 MF	300-1904	5
C6	10 MF 16VDC	300-3006	1
D	SIL DIODE	380-1001	55

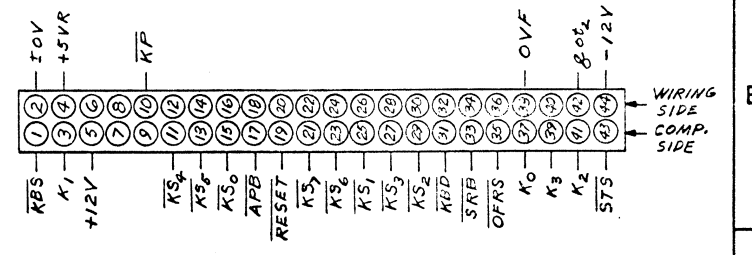

WANG LABORATORIES INC.
TEWKSBURY, MASS.

MODEL NO. 100
DRAWN: 1/24/72
CHECKED: G.T.C.
DATE: 2/2/72

TITLE: SCHEMATIC LOGIBLOC #5953
UNIVERSAL SUBROUTINE

SHT OF: D
Dwg. No. 5953-1
REV.

NO.	REVISION

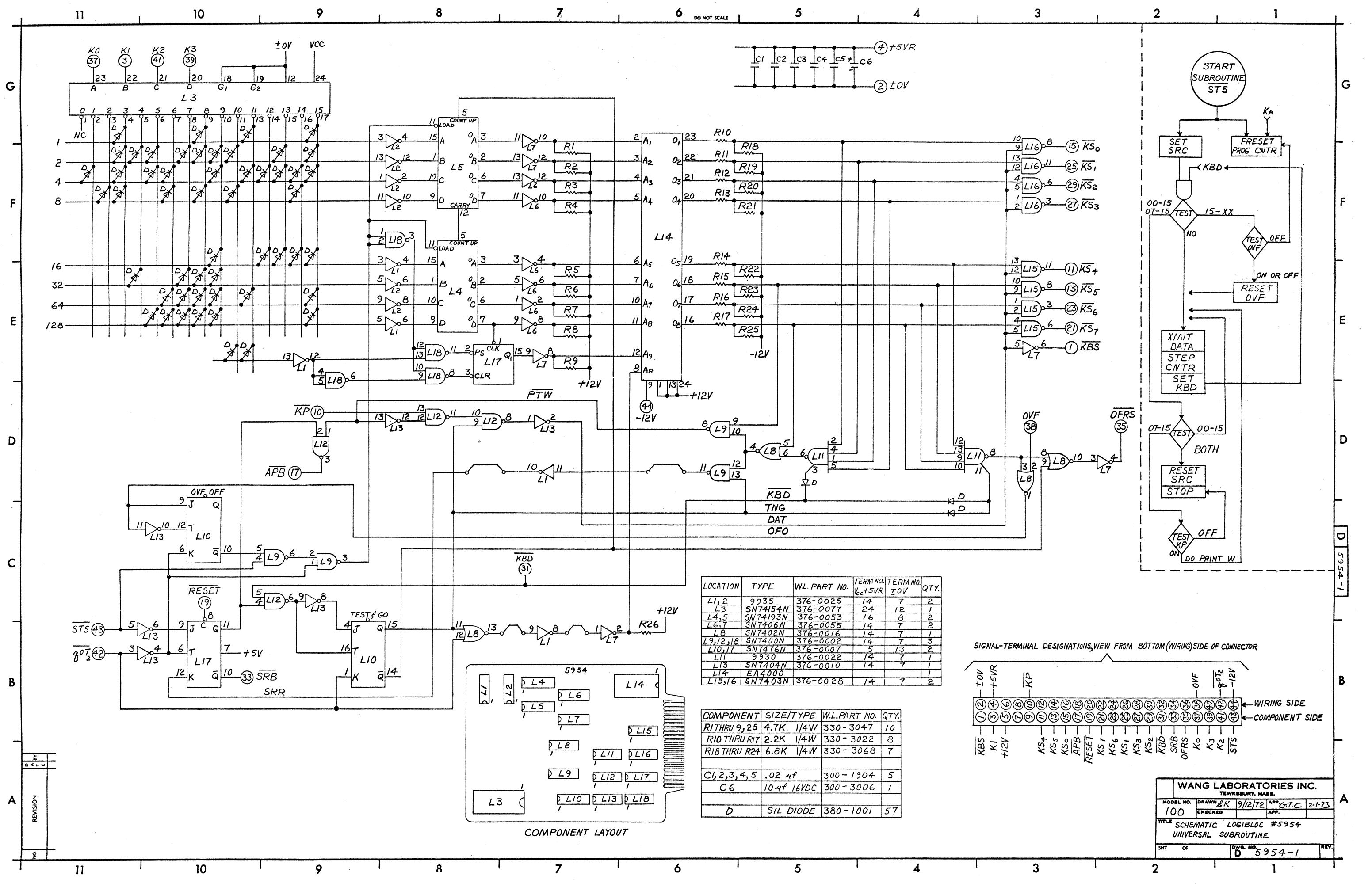

LOCATION	TYPE	WL. PART NO.	TERM. NO. $V_{cc}+5VR$	TERM. NO. $\pm 0V$	QTY.
L1,2	9935	376-0025	14	7	2
L3	SN74154N	376-0077	24	12	1
L4,5	SN74193N	376-0053	16	8	2
L6,7	SN7406N	376-0055	14	7	2
L8	SN7402N	376-0016	14	7	1
L9,12,18	SN7400N	376-0002	14	7	3
L10,17	SN7476N	376-0007	5	13	2
L11	9930	376-0022	14	7	1
L13	SN7404N	376-0010	14	7	1
L14	EA4000	376-0010	14	7	1
L15,16	SN7403N	376-0028	14	7	2

COMPONENT	SIZE/TYPER	WL. PART NO.	QTY.
R1 THRU R25	4.7K 1/4W	330-3047	10
R10 THRU R17	2.2K 1/4W	330-3022	8
R18 THRU R24	6.8K 1/4W	330-3068	7
C1,2,3,4,5	.02 μ f	300-1904	5
C6	10 μ f 16VDC	300-3006	1
D	SIL DIODE	380-1001	57

SIGNAL-TERMINAL DESIGNATIONS, VIEW FROM BOTTOM (WIRING) SIDE OF CONNECTOR

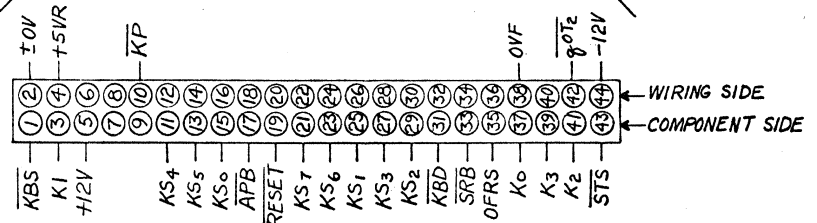

WANG LABORATORIES INC. TEWKSBURY, MASS.			
MODEL NO. 100	DRAWN BY K	9/12/72	APP. G.T.C.
CHECKED	APP.	2-1-73	
TITLE SCHEMATIC LOGIBLOC #5954 UNIVERSAL SUBROUTINE			
SHT OF	DWG. NO. D 5954-1	REV.	

NO.	REVISION

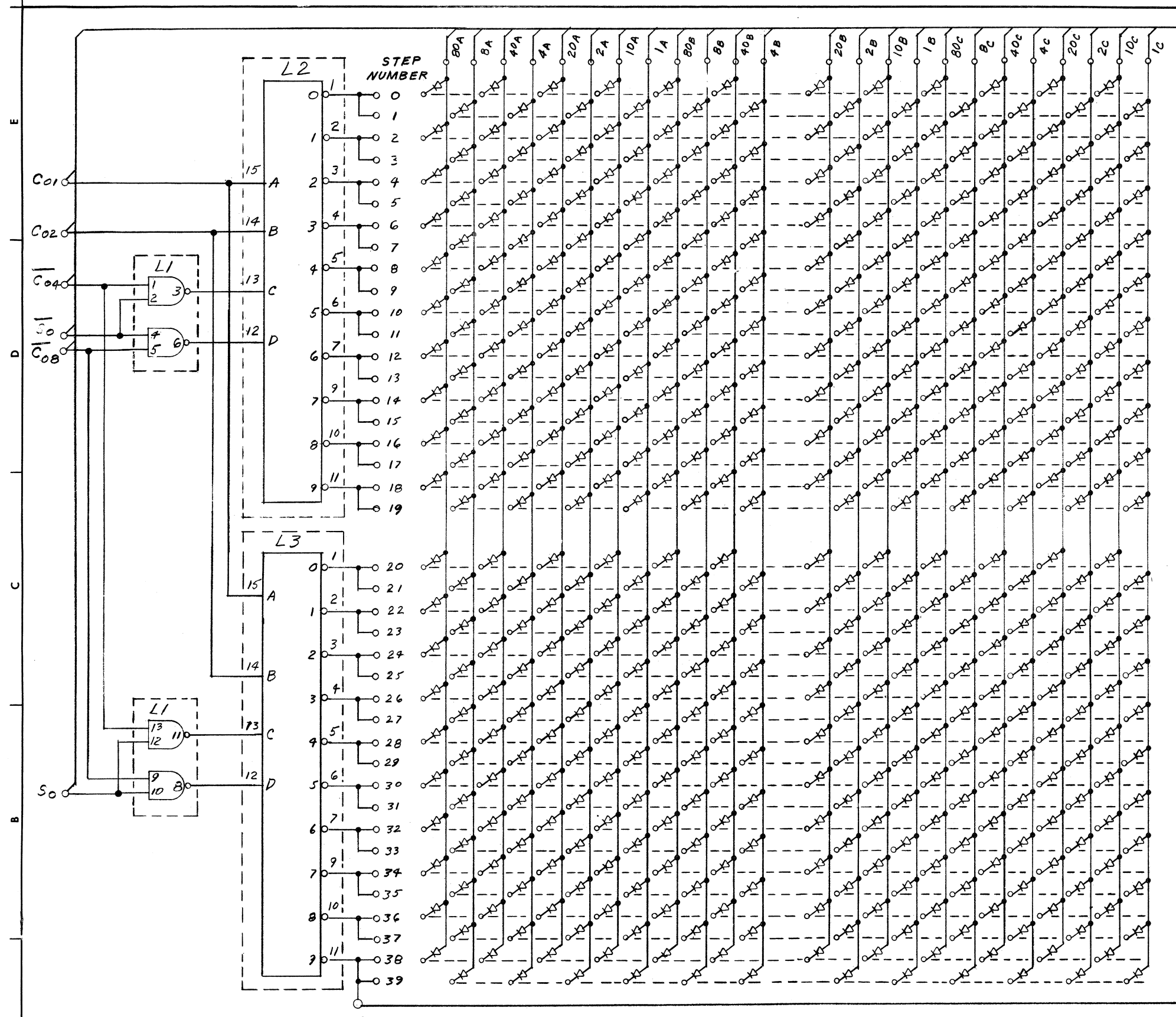

PLUG-IN TERMINAL END
WANG PART No. 595B

1A	2
2A	5
4A	11
8A	17
10A	44
20A	39
40A	38
80A	32
1B	4
2B	3
4B	9
8B	15
10B	42
20B	41
40B	36
80B	30
1C	6
2C	1
4C	7
8C	13
10C	40
20C	43
40C	34
80C	28
±0V	31
+5VR	35
C01	10
C02	8
C04	21
C08	19
S0	23
S0	25
39	27

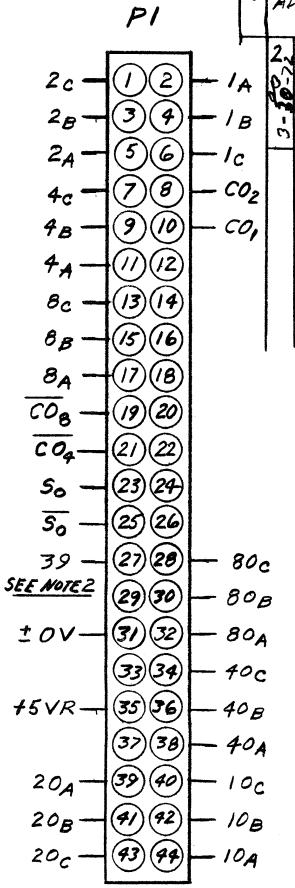

REVISIONS	
1	PER ECN #2121 ADDED P1, REMOVED ALL ARROWS FROM CONN. 3, REMOVED 1 FROM .05 CAP ADDED NOTE 2 APP: R T
2	PER ECN #2860 WAS .54F AND .05 ME APP: SKH

LOCATION	TYPE	WANG LAB. No.	TERM. No. V _{CC} +5VR	TERM. No. ±0V	TERM. No. GTY
L1	SN7400N	376-0002	14	7	1
L2, 3	SN7442N	376-0008	16	8	2

NOTE:
1. ALL DIODES ARE WL 380-1001 (QTY 480)
2. USED ONLY ON MODEL 704 CARD READER

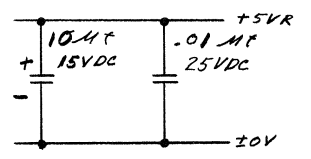
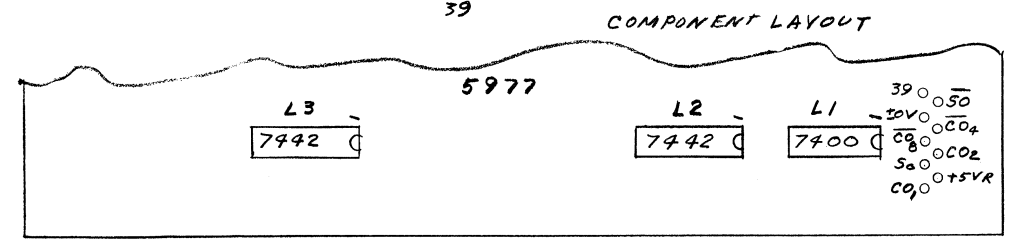

TOL. EX. AS NOTED .XX ±.010 .XXX ±.008	FRAC. ±/1 ANG. ±
MATERIAL	
FINISH	SCALE

WANG LABORATORIES INC. TEWKSBURY, MASS.			
MODEL NO.	DRAWN <i>GB</i> 3/9/71	APP. G.T.C. 3/12/70	
	CHECKED	APP.	
TITLE SCHEMATIC LOGIBLOC # 5977			
CARD READER FOR MODEL 184, 185 AND 704			
PT. NO. 210-5977	DWG. NO. C	5977-1	REV. 2

7
6
5
4
3
2
1

ON 5MG

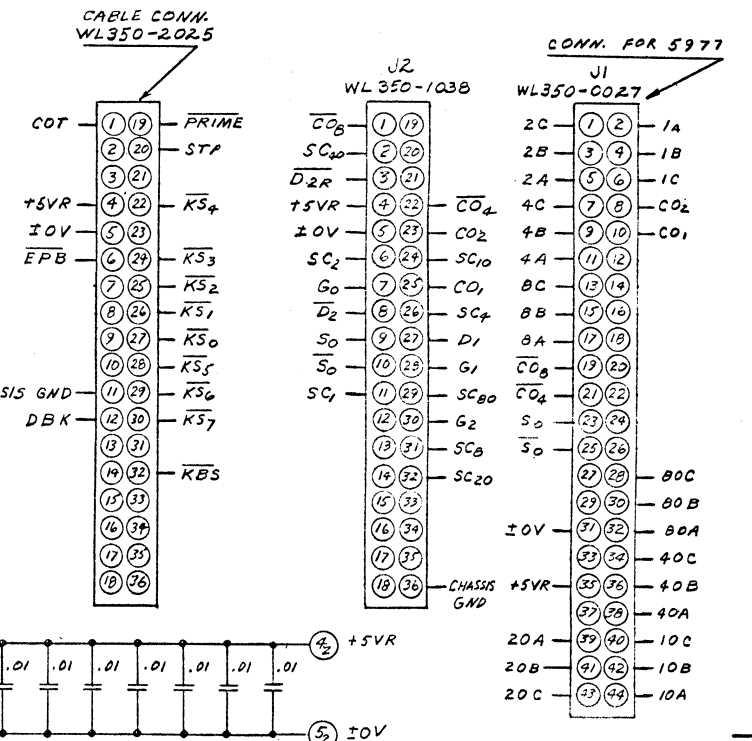
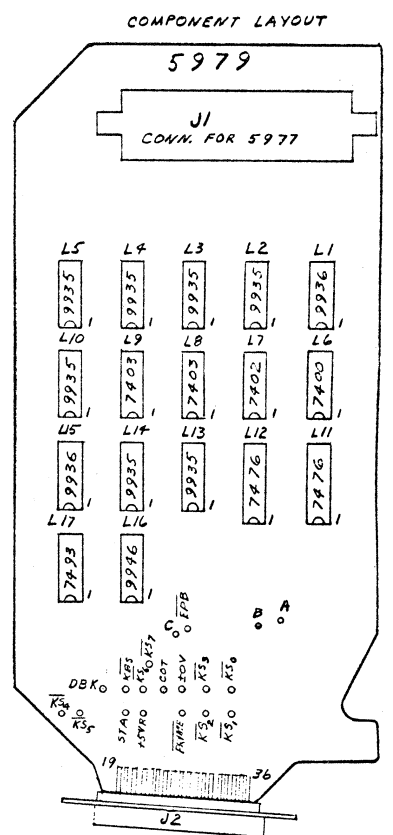
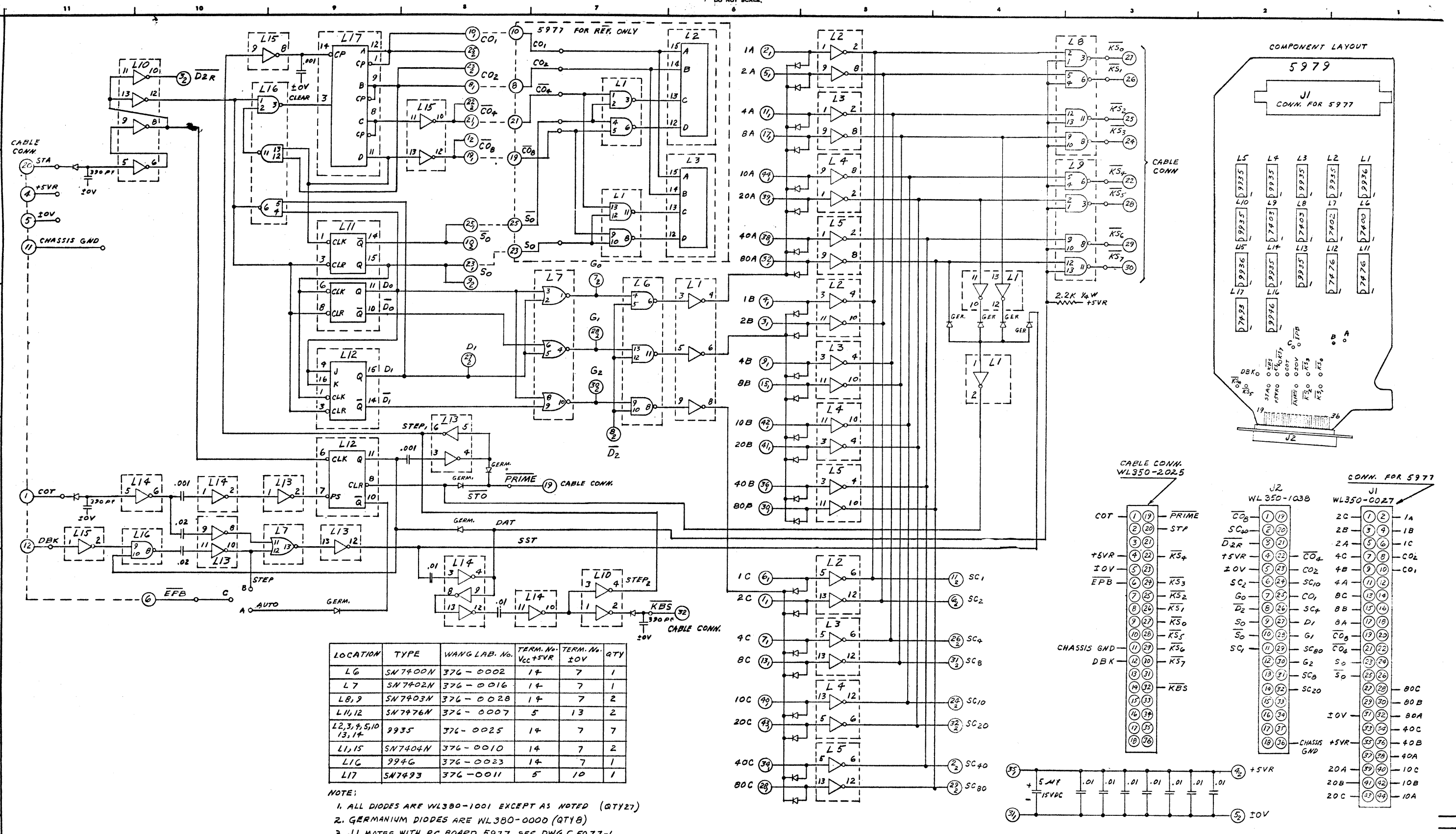

LOCATION	TYPE	WANG LAB. No.	TERM. No. Vcc +SVR	TERM. No. IOV	QTY
L6	SN7400N	376-0002	14	7	1
L7	SN7402N	376-0016	14	7	1
L8,9	SN7403N	376-0028	14	7	2
L11,12	SN7476N	376-0007	5	13	2
L2,3,7,5,10,13,14	9935	376-0025	14	7	7
L1,15	SN7404N	376-0010	14	7	2
L16	9946	376-0023	14	7	1
L17	SN7493	376-0011	5	10	1

- NOTE:
1. ALL DIODES ARE WL380-1001 EXCEPT AS NOTED (QTY27)
 2. GERMANIUM DIODES ARE WL380-0000 (QTY8)
 3. J1 MATES WITH P.C. BOARD 5977. SEE DWG C 5977-1
 4. J2 MATES WITH CABLE CONNECTOR FROM P.C. BOARD 5980 SEE DWG. C 5980-1

REVISION	DATE	BY	DESCRIPTION
1	7/20/71	JX	PER ECN 2272 ADDED 2 SIL DIODES, ADDED 3.980 PF CAP APP. - G.F.C.
2	8-15-72	JX	PER ECN 2799 LI AND L15 WERE 9935, AT L14 WERE 9946, AT L11 WERE 9935, DIODES (L1, L15) APP. SK-HO

IDENT	QTY	NAME	MATERIAL	DESCRIPTION
DR		WANG LABORATORIES, INC.		DATE 3/17/71
CHK		TEWKSBURY, MASS. U. S. A.		DATE 5-20-71
APPD		G.T.C.		DATE 5/20/71
MODEL No. 184		W.O. No.	SCALE 1/1	SHEET 1 OF 1
TITLE		SCHEMATIC LOGIBLOC, CARD READER # 5979		
210-5979		2	D	5979-1
PART NUMBER		REV	SIZE	DRAWING NUMBER

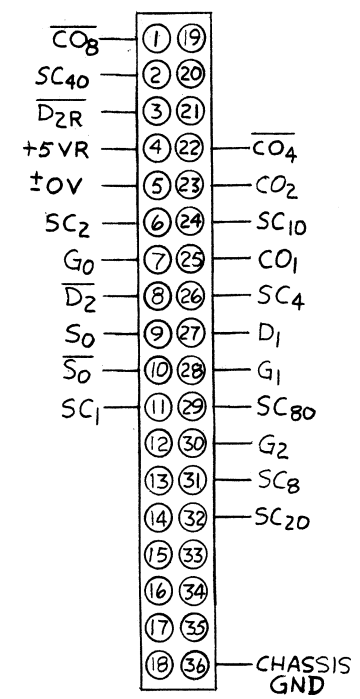
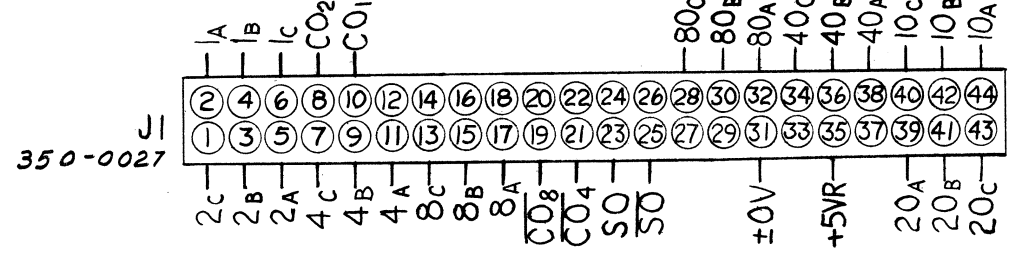
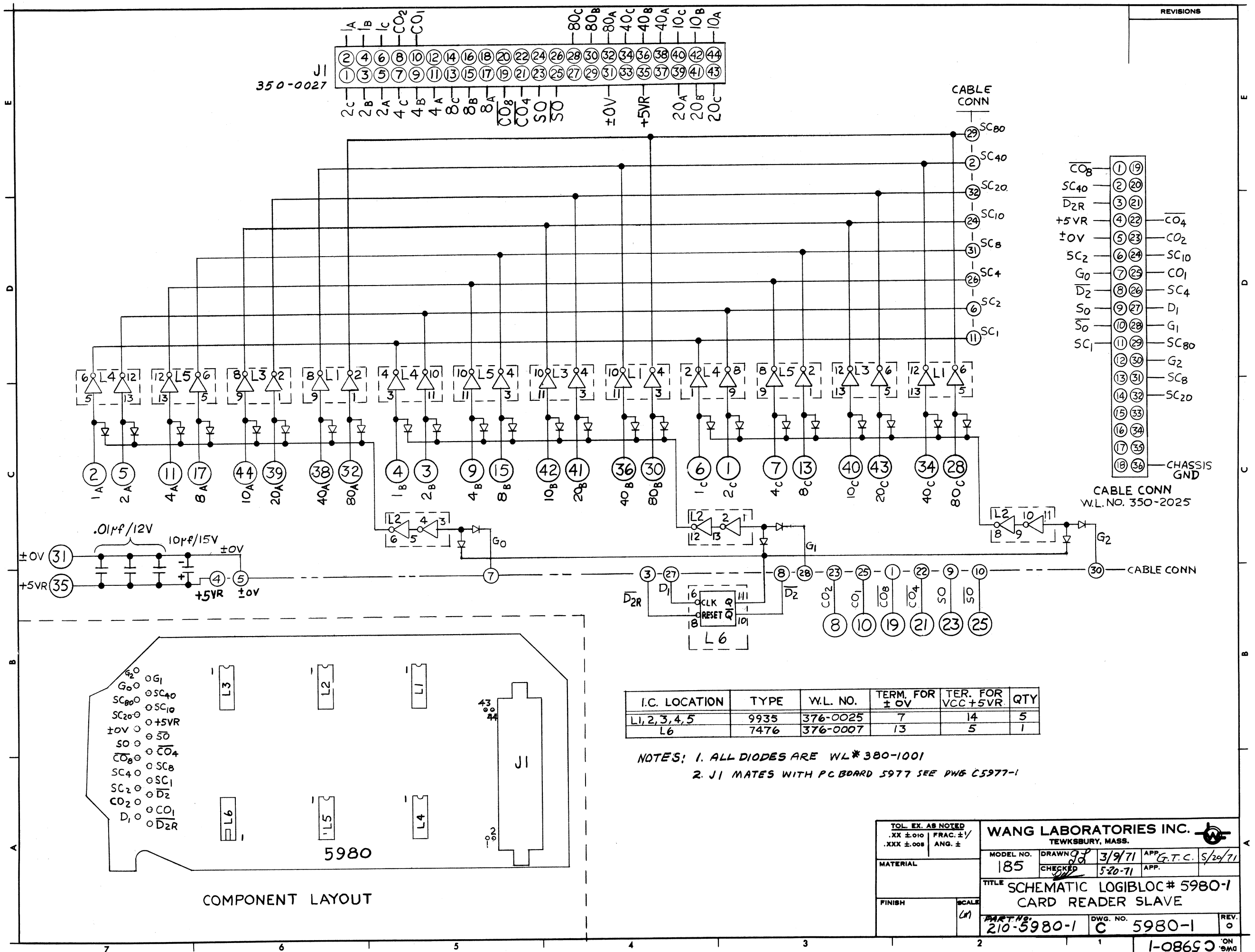

I.C. LOCATION	TYPE	W.L. NO.	TERM. FOR ±0V	TER. FOR VCC+5VR	QTY
L1, 2, 3, 4, 5	9935	376-0025	7	14	5
L6	7476	376-0007	13	5	1

NOTES: 1. ALL DIODES ARE WL*380-1001
 2. J1 MATES WITH PC BOARD 5977 SEE DWG C5977-1

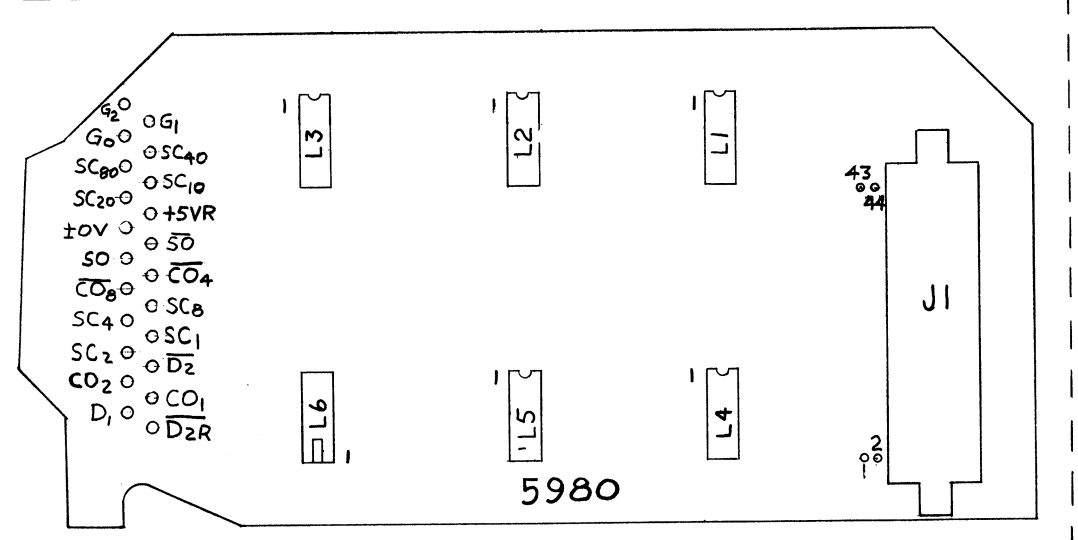

COMPONENT LAYOUT

TOL. EX. AS NOTED .XX ±.010 PRAC. ±1/2 .XXX ±.008 ANG. ±		WANG LABORATORIES INC. TEWKSBURY, MASS.	
MATERIAL	MODEL NO. 185	DRAWN 9/3/71	APP. G.T.C. 5/29/71
FINISH	CHECKED	5-20-71	APP.
TITLE SCHEMATIC LOGIBLOC# 5980-1 CARD READER SLAVE			
PART NO. 210-5980-1	DWG. NO. C 5980-1	REV. 0	ON 9MG

DISPLAY CONN. ← DWG. 5951-1

SOLDER POINTS ←

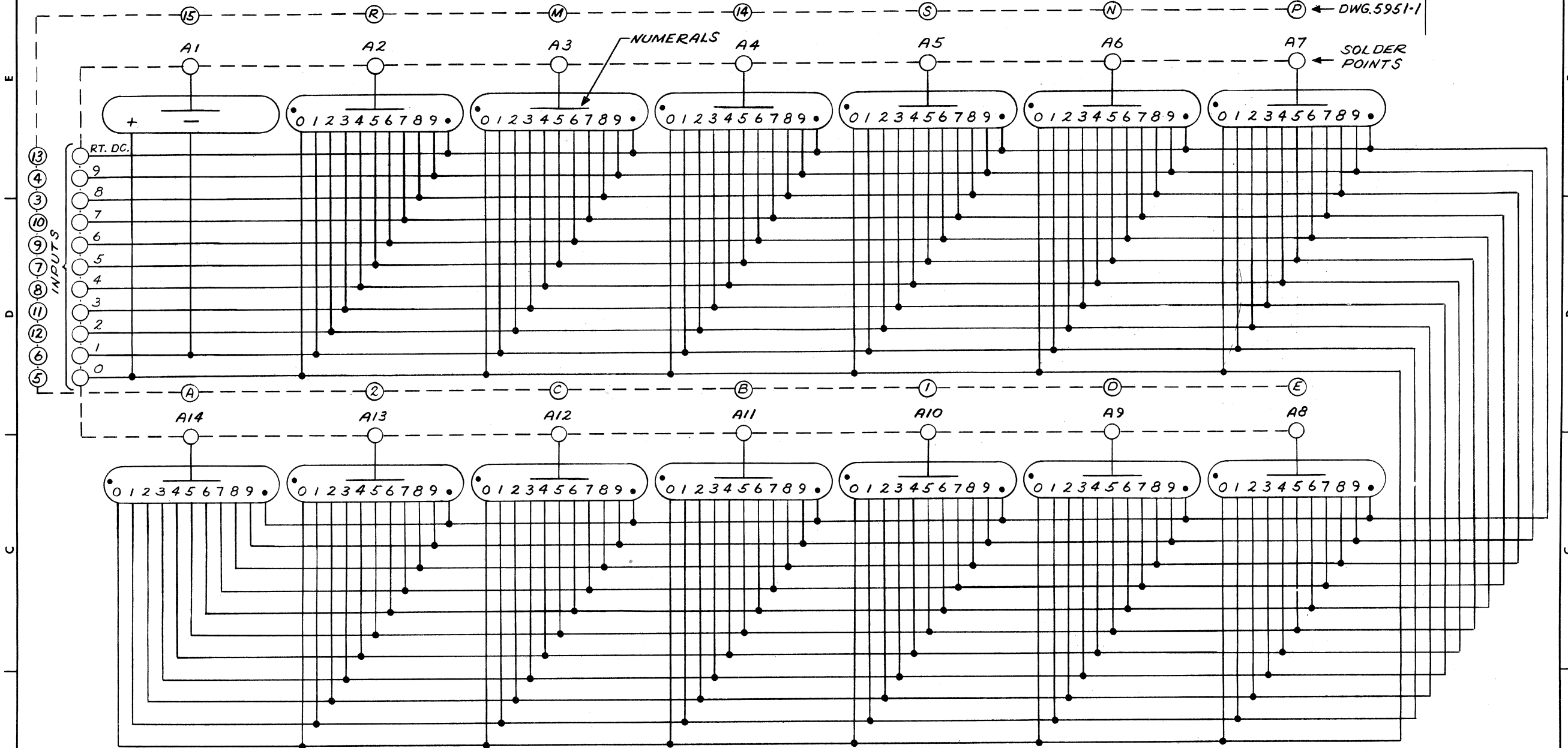

BOTTOM VIEW
SK-207 W.L. #341-0016
PIN NUMBERS

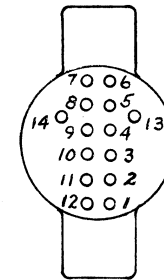

PIN	CONNECTION	SIGN TUBE
1	NUMERAL 1	-
2	NUMERAL 2	
3	NUMERAL 3	
4	NUMERAL 4	
5	NUMERAL 5	
6	NUMERAL 6	+
7	ANODE	ANODE
8	NUMERAL 7	
9	NUMERAL 8	
10		
11	NUMERAL 9	
12	NUMERAL 0	
13	RIGHT DC. PT.	
14		

TUBE TYPE	W.L. NO.	QTY.
NUMERAL	340-0011	13
SIGN	340-0010	1

WANG LABORATORIES INC.
TEWKSBURY, MASS.

MODEL NO. 100
DRAWN F.S.S. 3-23-71
CHECKED R.L. 3-31-71

APP. G.T.C. 3-31-71
APP.

TITLE
SCHEMATIC LOGIBLOC #5985
NIXIE DISPLAY

W.O. NO. C 5985-1
REV.

REVISIONS	
REVISED: PER	E.C. #2085
4-16-71 F.S.S.	APP'D. RT
REVISED: PER	E.C. #2494 F.S.S.
10-13-71 APP'D.	G.T.C.

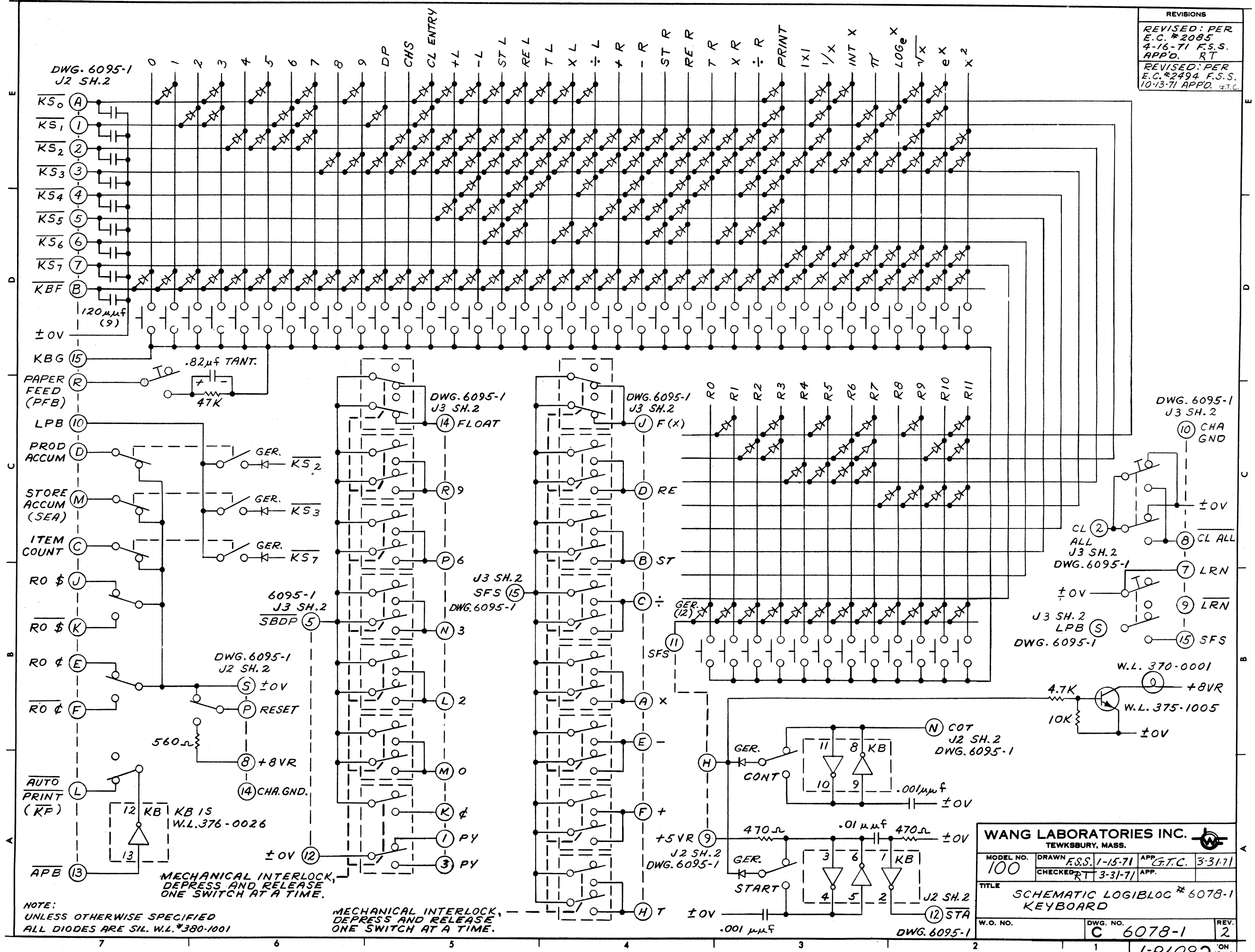

NOTE:
UNLESS OTHERWISE SPECIFIED
ALL DIODES ARE SIL. W.L. #380-1001

MECHANICAL INTERLOCK,
DEPRESS AND RELEASE
ONE SWITCH AT A TIME.

WANG LABORATORIES INC.
TEWKSBURY, MASS.

MODEL NO.	100	DRAWN	F.S.S. 1-15-71	APP.	G.T.C. 3-31-71
CHECKED	RT 3-31-71	APP.			

TITLE: SCHEMATIC LOGIBLOC # 6078-1
KEYBOARD

W.O. NO.	DWG. NO.	REV.
	C 6078-1	2

1-82093 ON 9M0

REVISIONS	DATE
REVISED: PER E.C.*2207 F.S.S. APP'D RJT	6 15 71
REVISED: PER E.C.*2262 F.S.S. APP'D RJT	7 1 71

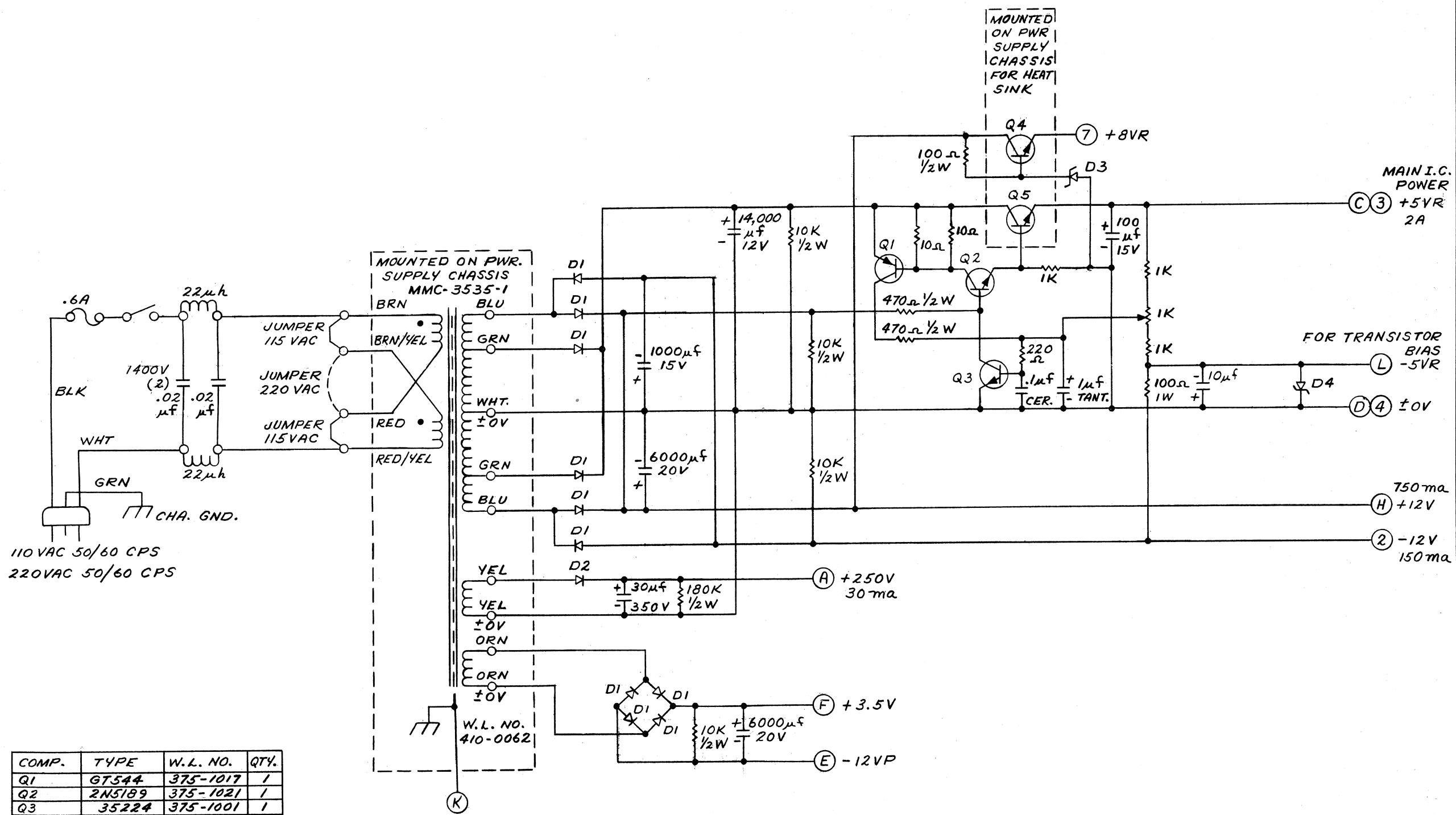

COMP.	TYPE	W.L. NO.	QTY.
Q1	GT544	375-1017	1
Q2	2N5189	375-1021	1
Q3	35224	375-1001	1
Q4	40250	375-1022	1
Q5	40251	375-1008	1
D1	1N4719	380-3002	10
D2	1N3255	380-3001	1
D3	9.1V ZENER	380-2091	1
D4	5.1V ZENER	380-2052	1

NOTE:
 1. ALL RESISTORS ARE 1/4W UNLESS OTHERWISE SPECIFIED.
 2. PIN ASSIGNMENTS INDICATED ARE IN REFERENCE TO PC 6097 WHICH IS A PART OF THE PWR. SUPPLY ASSY.

WANG LABORATORIES INC.
 TEWKSBURY, MASS.

MODEL NO. 100
 DRAWN F.S.S. 2-10-71
 CHECKED RT 3-31-71
 APP. G.T.C. 3-31-71

TITLE
 SCHEMATIC LOGIBLOC *6079-1
 POWER SUPPLY FOR MOD. 100

W.O. NO. C 6079-1
 DWG. NO. 6079-1
 REV. 2

1-62093 ON 9MG

6095

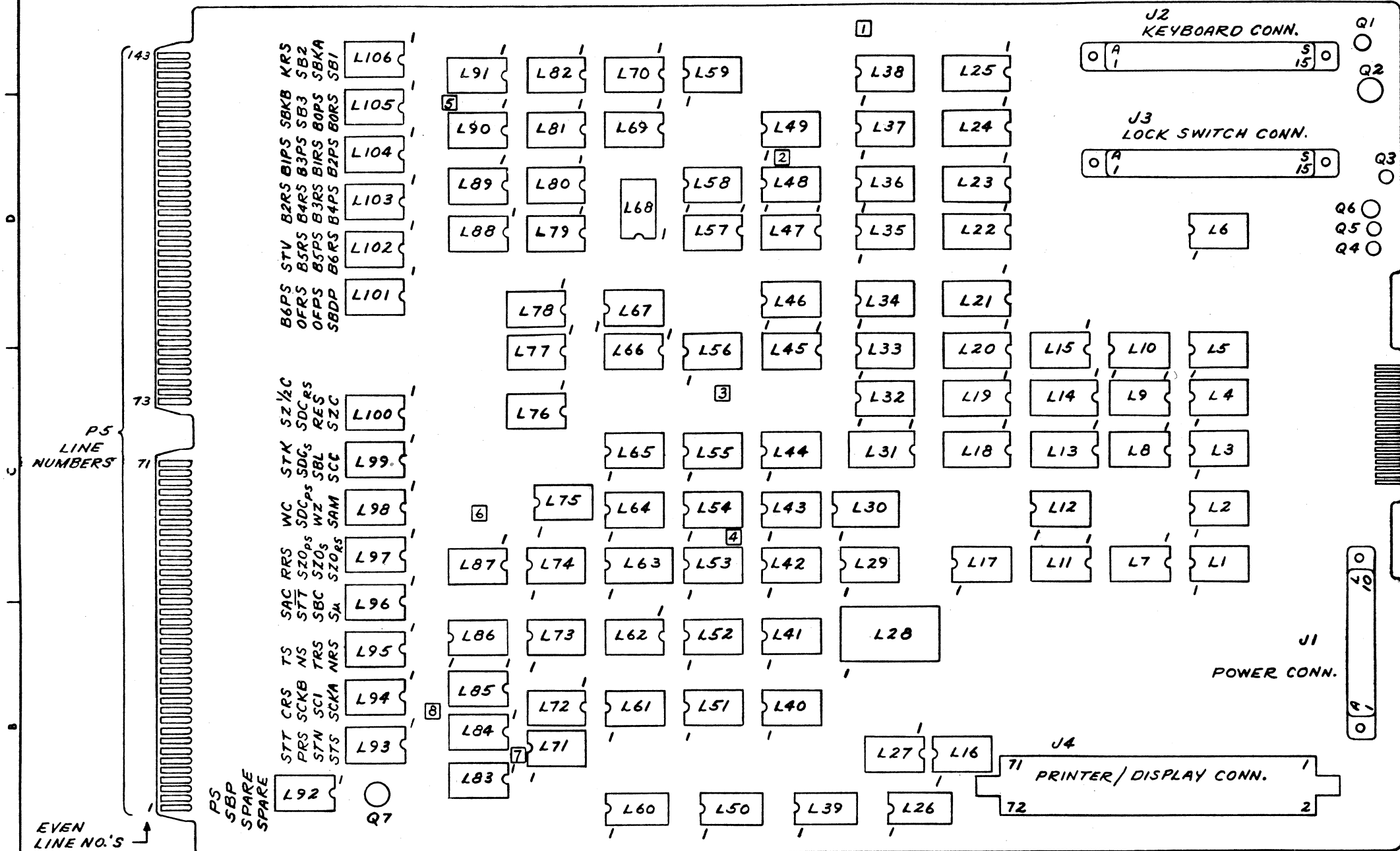

EVEN
LINE NO.'S
0 THRU 142 ON
OPPOSITE SIDE

□ SYMBOL FOR TEST POINTS

- 1. KBD
- 2. ZK
- 3. SZC
- 4. ZO
- 5. gopit
- 6. r_o
- 7. n_o
- 8. t_o

WANG LABORATORIES INC.
TEWKSBURY, MASS.

MODEL NO. 100	DRAWN F.S.S. 12-8-70	APP. G.T.C. 3-31-71
CHECKED RT 3-31-71		APP.
TITLE BOARD LAYOUT FOR 6095		
W.O. NO.	DWG. NO. C6095-1	REV. SH10F12 4

1-56095 ON 9MG

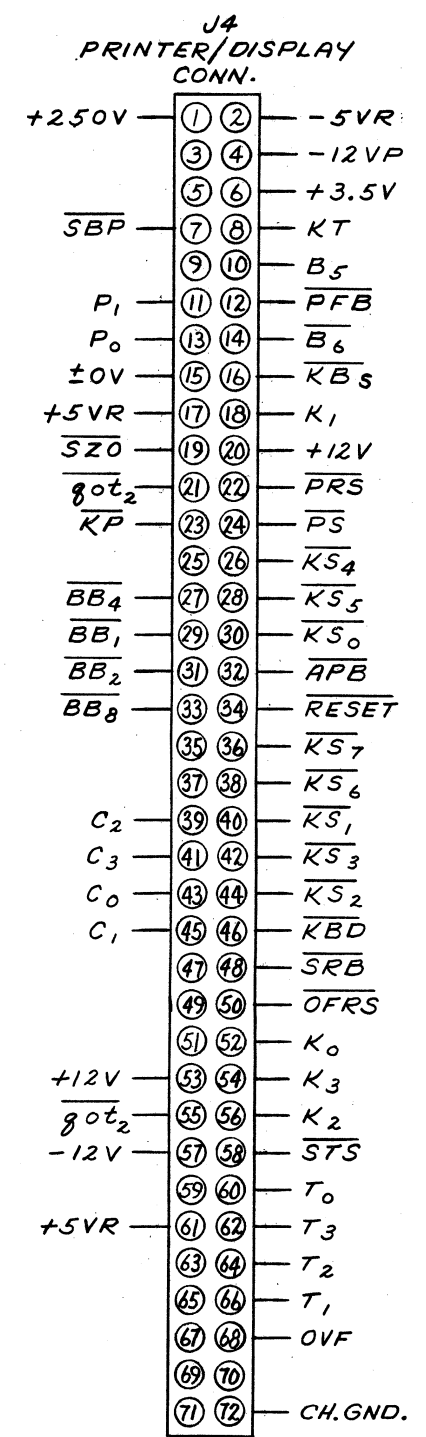
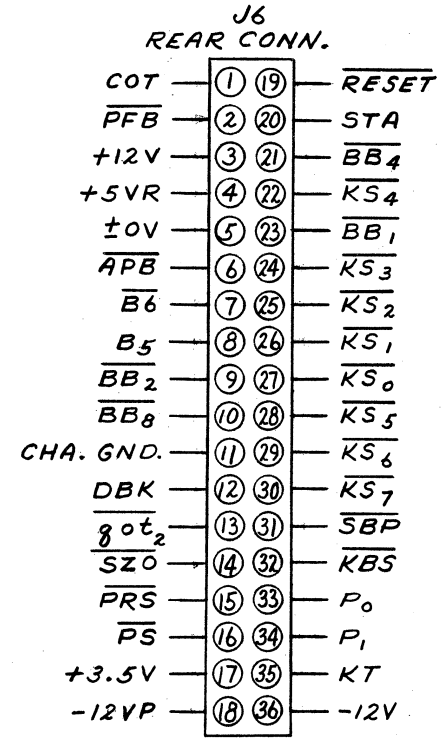
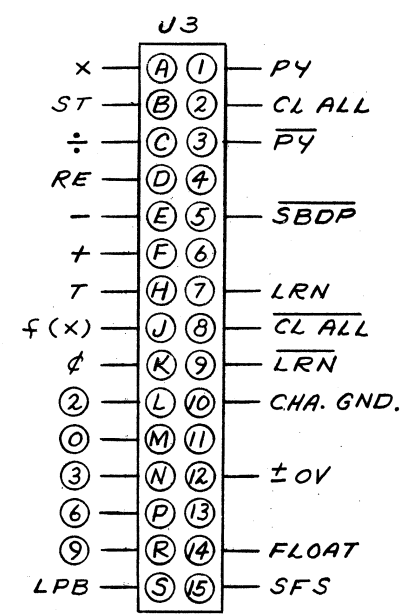
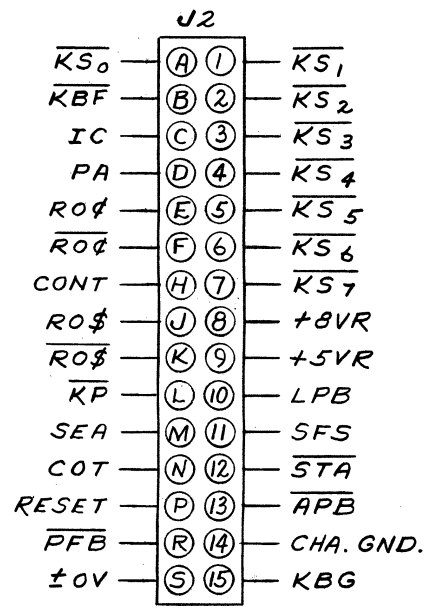
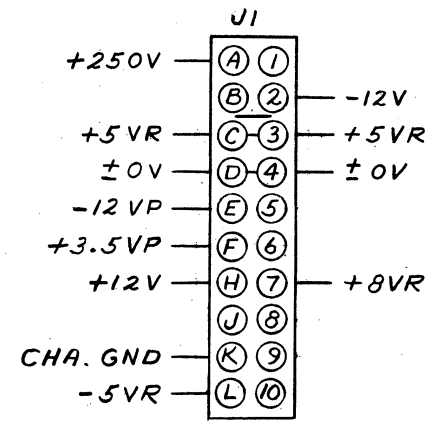

WANG LABORATORIES INC.
TEWKSBURY, MASS.

MODEL NO.	DRAWN	DATE	APP.
100	F.S.S.	12-10-70	G.T.C.
	CHECKED	3-31-71	APP.

TITLE
PLUG/CONNECTOR LAYOUT
FOR P.C. #6095-1

W.O. NO.	DWG. NO.	REV.
	C6095-1 SH20F12	4

1-56090

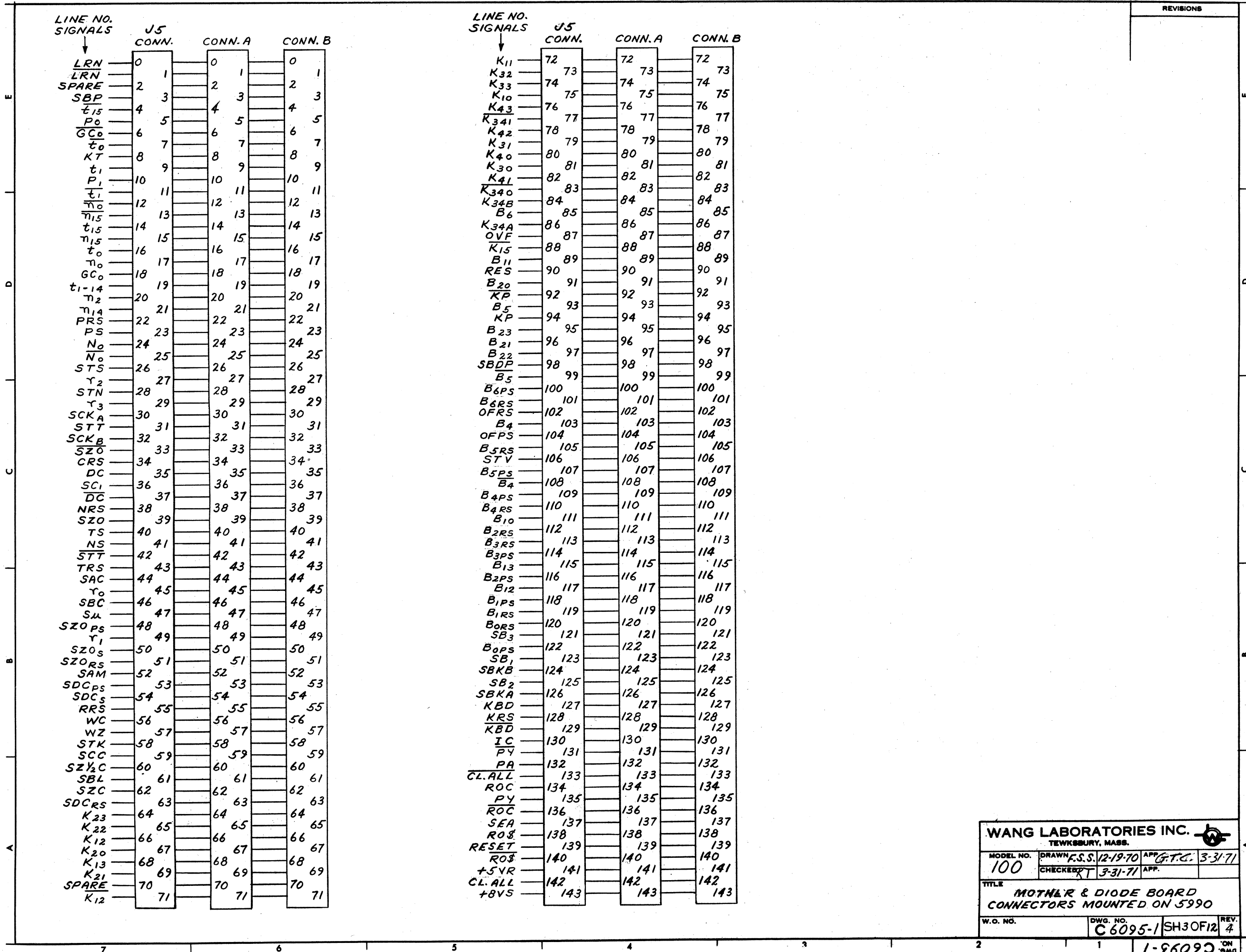

WANG LABORATORIES INC.			
TEWKSBURY, MASS.			
MODEL NO.	DRAWN F.S.S. 12-19-70	APP. G.T.C. 3-31-71	
100	CHECKED BY T 3-31-71	APP.	
TITLE			
MOTHER & DIODE BOARD CONNECTORS MOUNTED ON 5990			
W.O. NO.	DWG. NO.	REV.	
	C 6095-1/SH30F12	4	

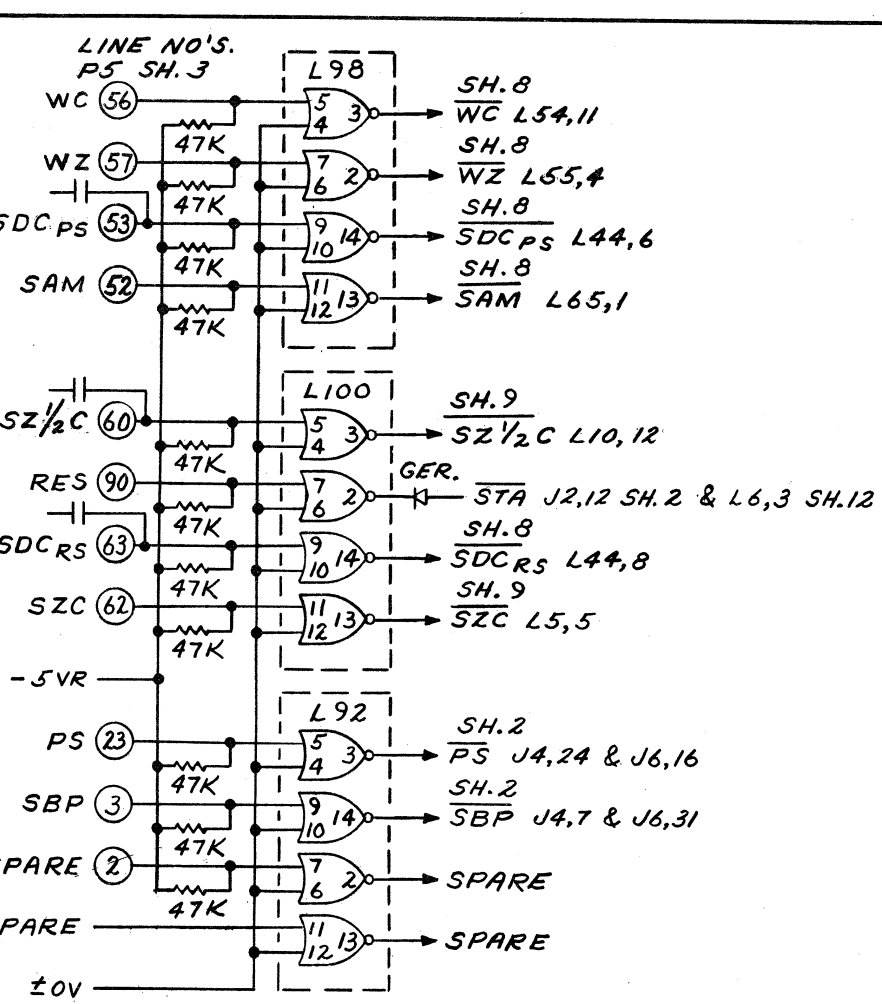
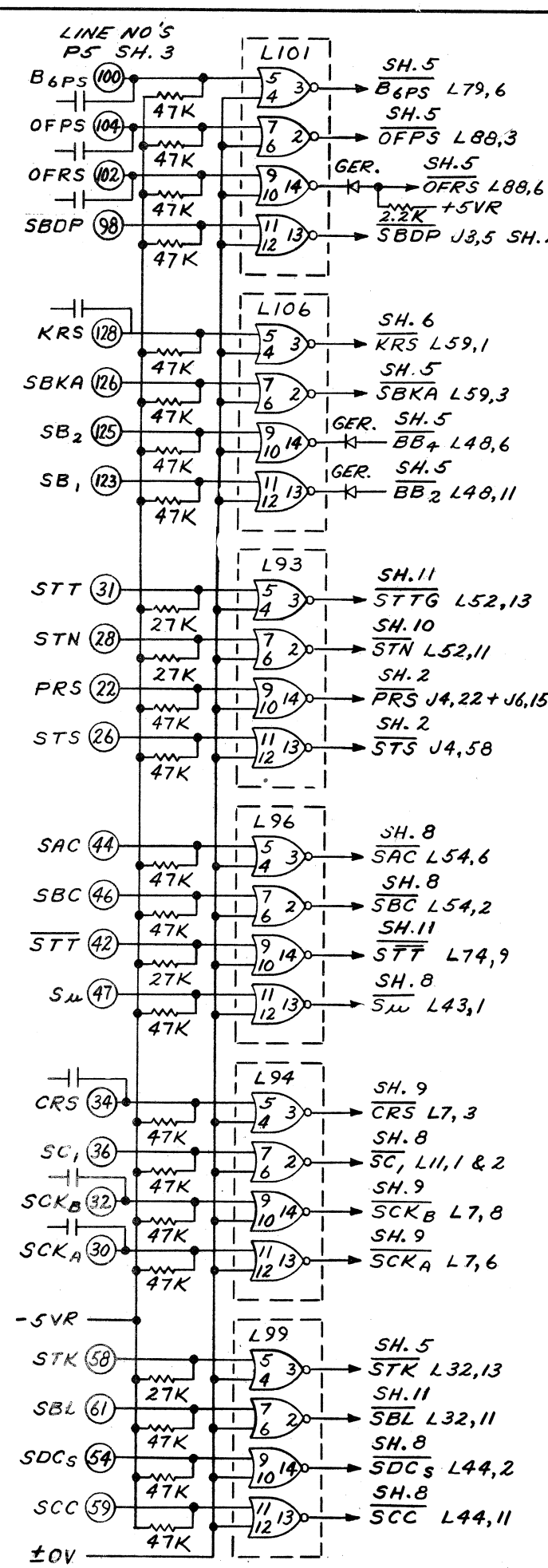
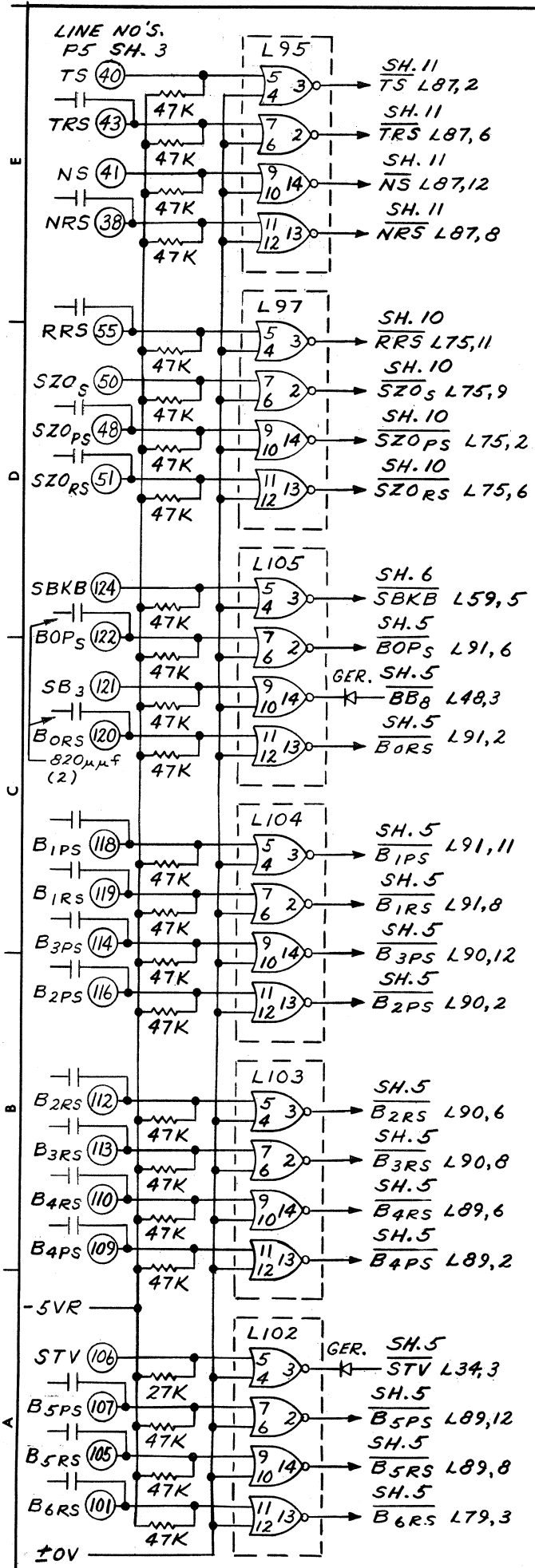

REVISIONS
 REVISED: PER
 E.C.*2518 F.S.S.
 10-20-71 APP'D GTC

NOTE:
 QUALITIES THAT ARE SHOWN IN THESE
 CHARTS ARE IN SOME CASES DUPLICATED AND
 THEREFORE DO NOT MAKE UP AN ACCURATE B.O.M.

I.C. LOCATION	TYPE	W.L. NO.	TERM FOR VCC +5V	TERM FOR ±0V	QTY.
L92,93,94,95,96,97,98,99,100,101,102,103,104,105,106	SP380A	376-0061	8	1	15

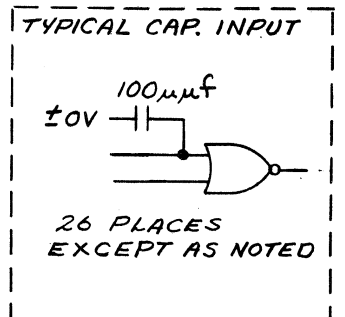

WANG LABORATORIES INC.
 TEWKSBURY, MASS.

MODEL NO. DRAWN F.S.S. 10-30-70 APP. J.T.C. 3-31-71
 CHECKED RT 3-31-71 APP.

TITLE BLOCK CIRCUIT DIAGRAM
 DIODE INTERFACE

W.O. NO. DWG. NO. C6095-1 SH 4 OF 12 REV. 4

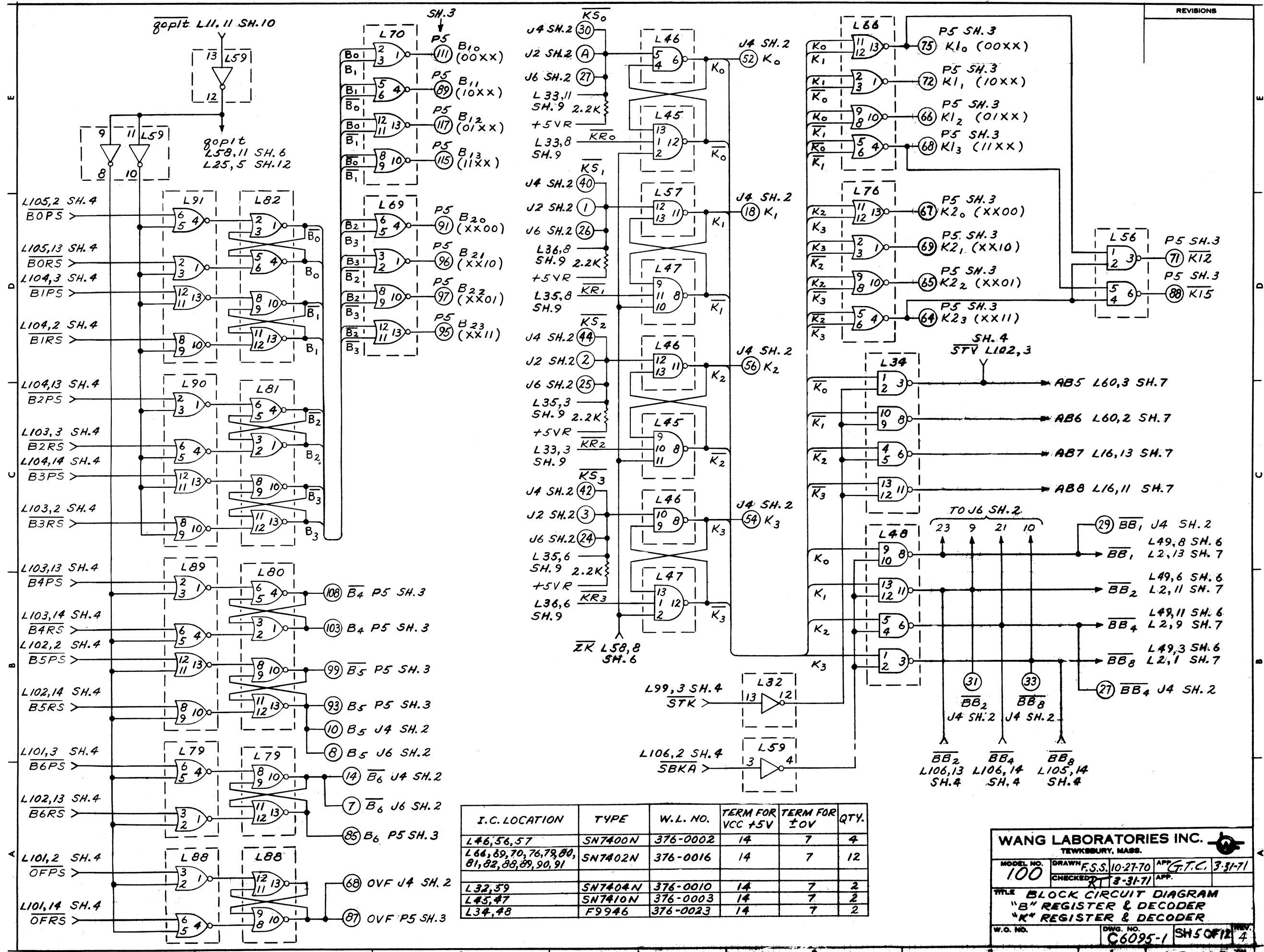

REVISIONS

I.C. LOCATION	TYPE	W.L. NO.	TERM FOR VCC +5V	TERM FOR ±0V	QTY.
L46,56,57	SN7400N	376-0002	14	7	4
L66,69,70,76,79,80,81,82,88,89,90,91	SN7402N	376-0016	14	7	12
L32,59	SN7404N	376-0010	14	7	2
L45,47	SN7410N	376-0003	14	7	2
L34,48	F9946	376-0023	14	7	2

WANG LABORATORIES INC.
TEWKSBURY, MASS.

MODEL NO. **100** DRAWN F.S.S. 10-27-70 APP. G.T.C. 3-31-71
CHECKED BY 3-31-71 APP.

TITLE **BLOCK CIRCUIT DIAGRAM**
"B" REGISTER & DECODER
"K" REGISTER & DECODER

W.O. NO. DWG. NO. **C6095-1 SH50F12 4**

1-56095

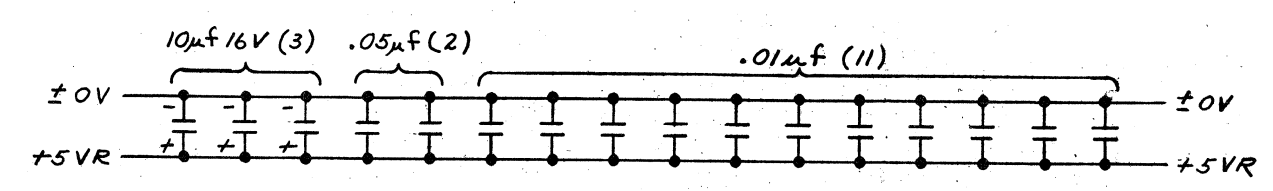
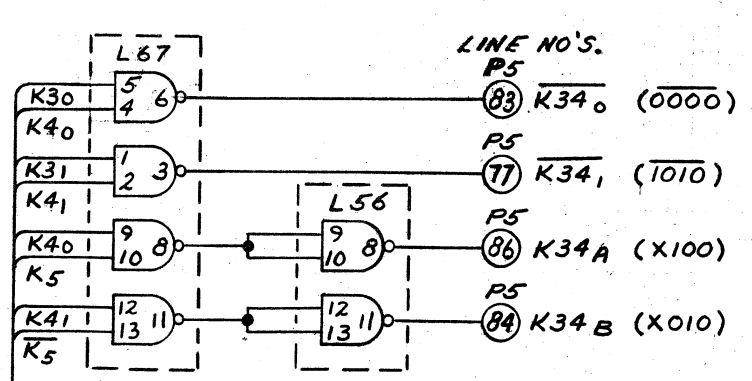
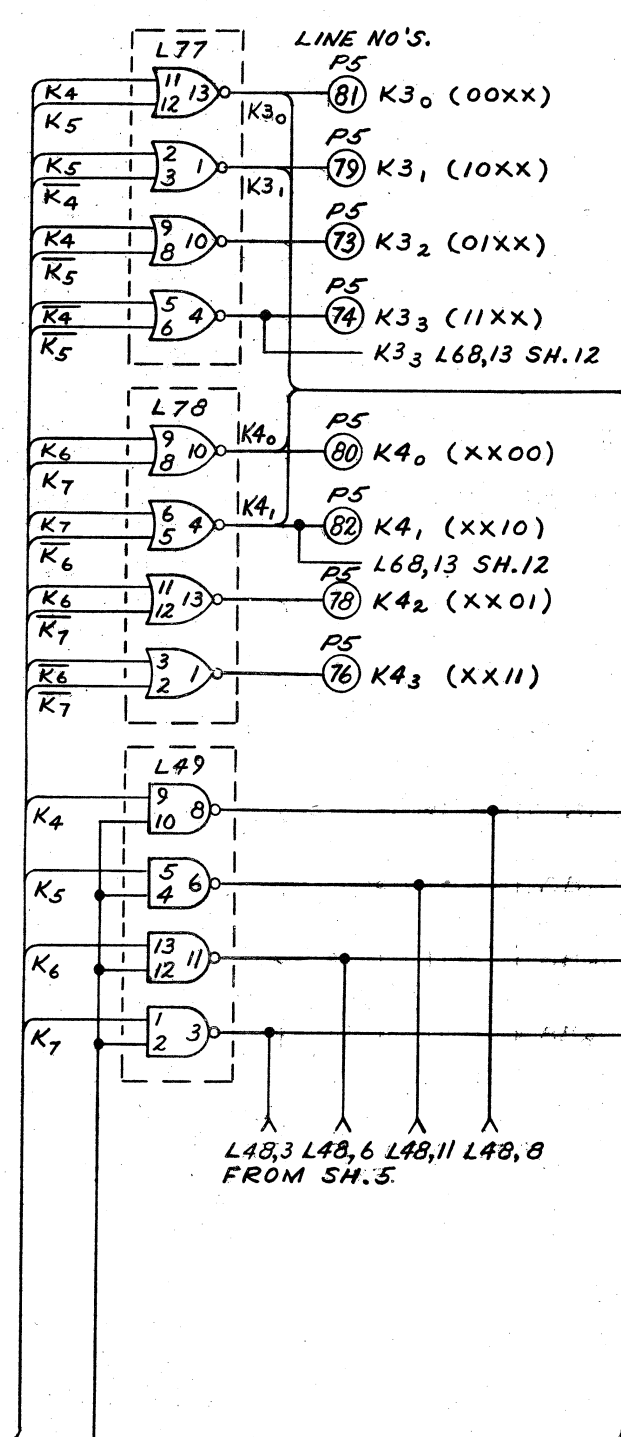
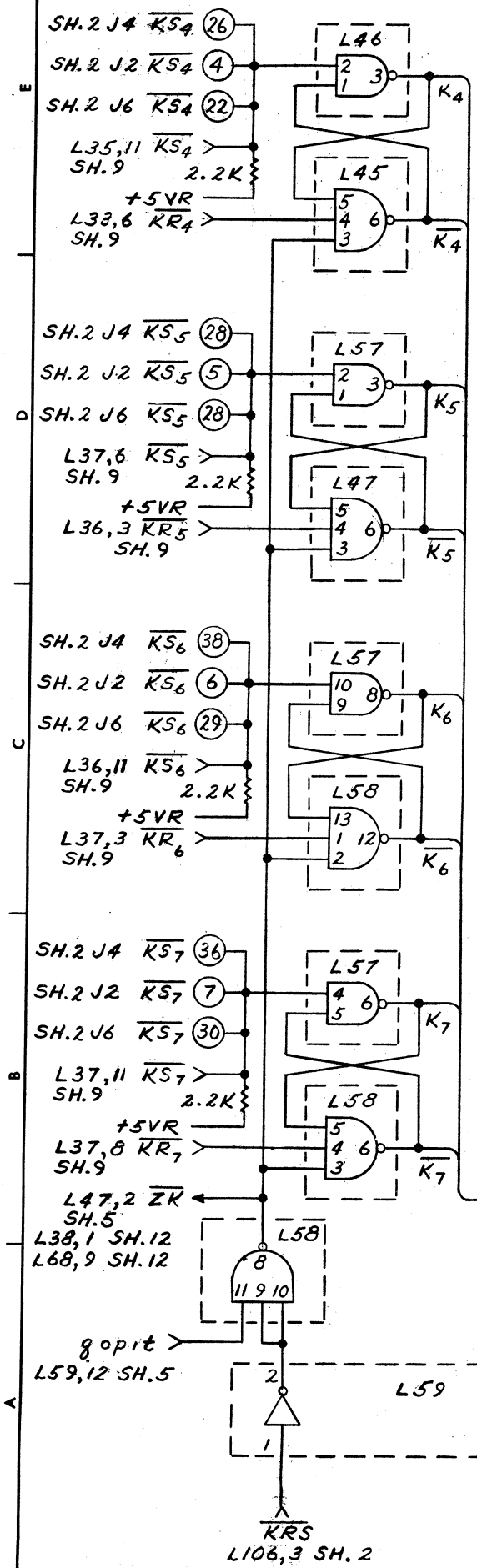

I. C. LOCATION	TYPE	W.L. NO.	TERM FOR VCC +5V	TERM FOR ±0V	QTY.
L46, 56, 57, 67	SN7400N	376-0002	14	7	4
L77, 78	SN7402N	376-0016	14	7	2
L49	F9946	376-0023	14	7	1
L59	SN7404N	376-0010	14	7	1
L45, 47, 58	SN7410N	376-0003	14	7	3

WANG LABORATORIES INC.
TEWKSBURY, MASS.

MODEL NO. 100
DRAWN F.S.S. 10-29-70
CHECKED BY 3-31-71
APP. T.C. 3-31-71

TITLE BLOCK CIRCUIT DIAGRAM
"B" REGISTER & DECODER
"K" REGISTER & DECODER

W.O. NO. C6095-1
DWG. NO. SM60F12
REV. 4

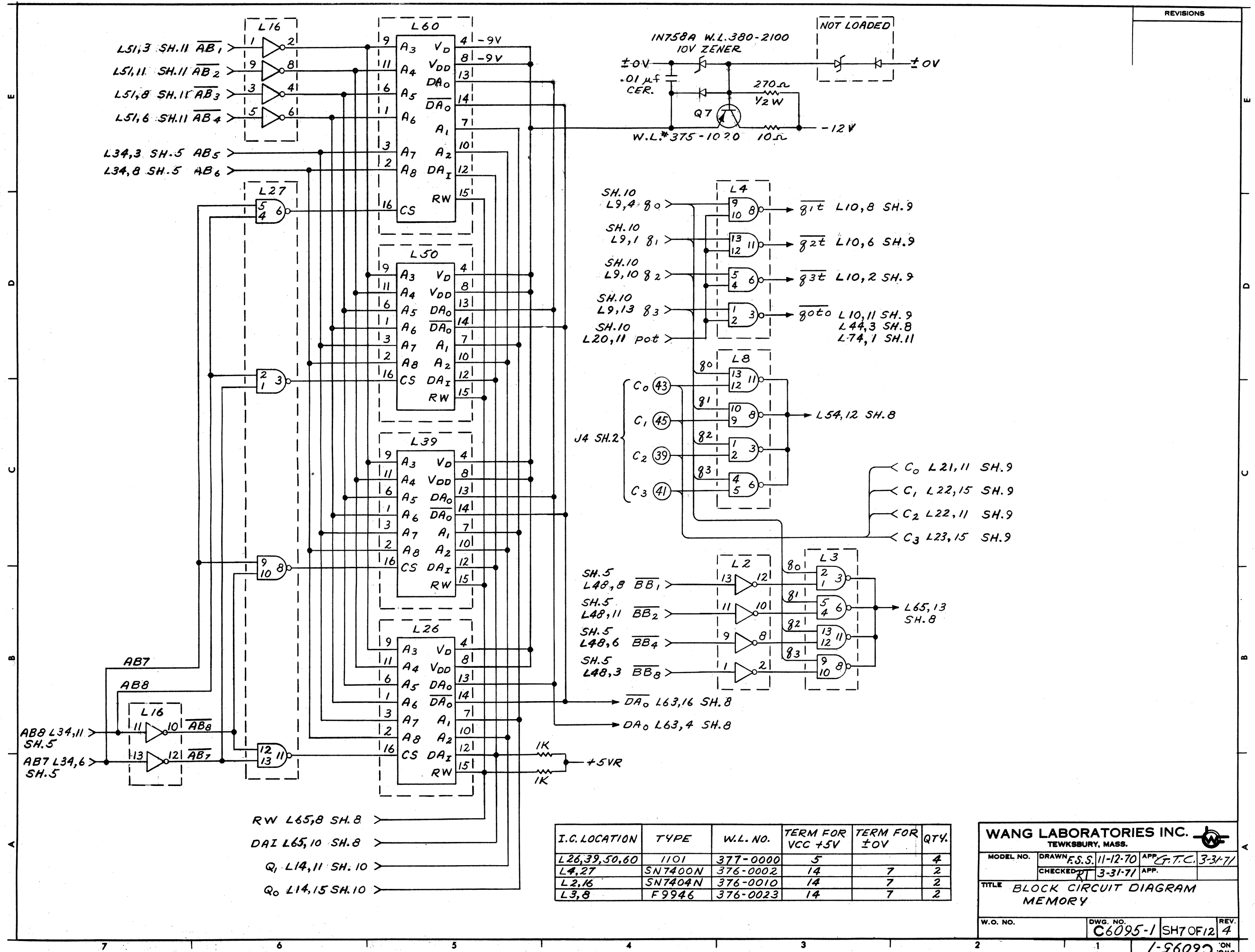

I.C. LOCATION	TYPE	W.L. NO.	TERM FOR VCC +5V	TERM FOR ±0V	QTY.
L26,39,50,60	1101	377-0000	5		4
L4,27	SN7400N	376-0002	14	7	2
L2,16	SN7404N	376-0010	14	7	2
L3,8	F9946	376-0023	14	7	2

WANG LABORATORIES INC.
TEWKSBURY, MASS.

MODEL NO. DRAWN F.S.S. 11-12-70 APP. F.T.C. 3-31-71
CHECKED RT 3-31-71 APP.

TITLE **BLOCK CIRCUIT DIAGRAM**
MEMORY

W.O. NO. DWG. NO. **C6095-1** SH7 OF 12 4
REV. ON 9MG

1-56090

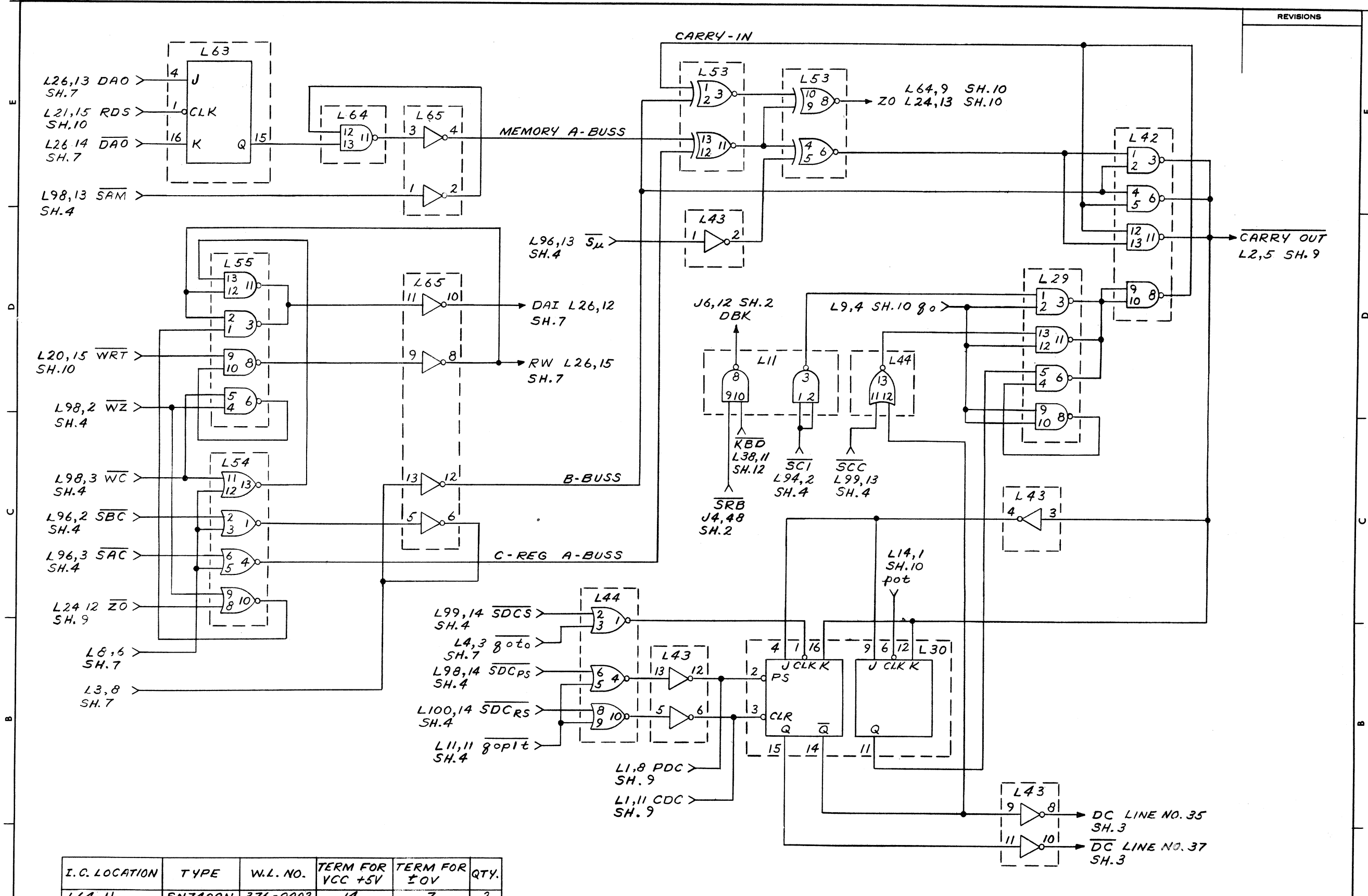

I.C. LOCATION	TYPE	W.L. NO.	TERM FOR VCC +5V	TERM FOR ±0V	QTY.
L64,11	SN7400N	376-0002	14	7	2
L44,54	SN7402N	376-0016	14	7	2
L30,63	SN7476N	376-0007	5	13	2
L53	SN7486N	376-0036	14	7	1
L65,43	F9936	376-0026	14	7	2
L55,42,29	F9946	376-0023	14	7	3

WANG LABORATORIES INC.
TEWKSBURY, MASS.

MODEL NO.	DRAWN	F.S.S. 11-18-70	APP	F.T.C. 3-31-71
	CHECKED	RT 3-31-71	APP.	

TITLE: **BLOCK CIRCUIT DIAGRAM**
ALU

W.O. NO. _____ DWG. NO. **C6095-1** SH8 OF 12 REV. **4**

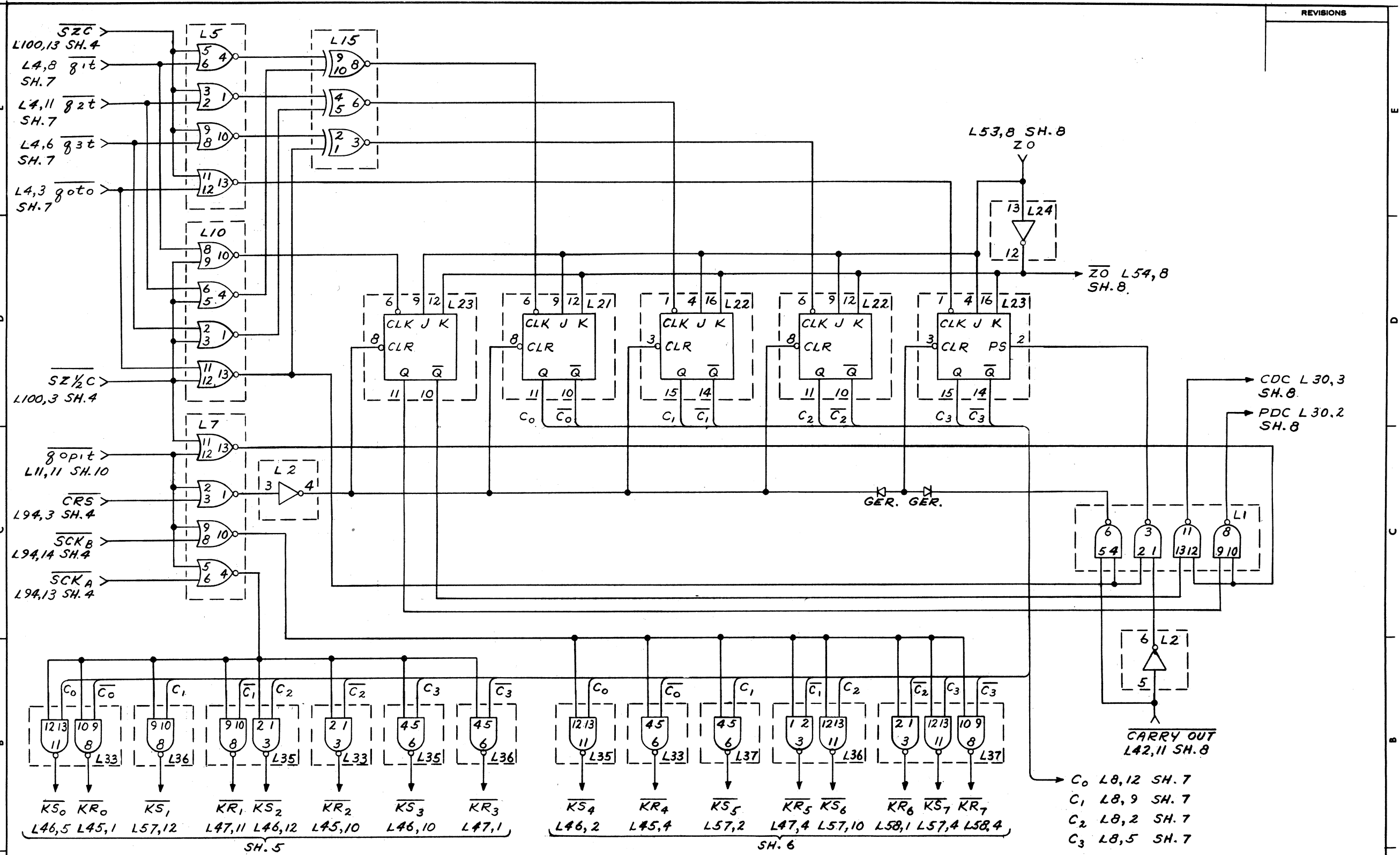

I.C. LOCATION	TYPE	W.L. NO.	TERM FOR VCC +5V	TERM FOR ±0V	QTY.
L5,7,10	SN7402N	376-0016	14	7	3
L2	SN7404N	376-0010	14	7	1
L21,22,23	SN7476N	376-0007	5	13	3
L15	SN7486N	376-0036	14	7	1
L24	F9935	376-0025	14	7	1
L1,33,35,36,37	F9946	376-0023	14	7	6

WANG LABORATORIES INC. TEWKSBURY, MASS.				
MODEL NO.	DRAWN	F.S.S. 11-14-70	APP. C.T.C.	3-31-71
	CHECKED	RT	3-31-71	APP.
TITLE BLOCK CIRCUIT DIAGRAM C-REGISTER				
W.O. NO.	DWG. NO.	C6095-1	SH90F12	REV. 4

REVISIONS	
REVISED: PER	E.C.#2445, F.S.S.
	9-23-71 APP'D. GTC
REVISED: PER	E.C.#2490, F.S.S.
	10-9-71 APP'D. GTC
REVISED: PER	E.C.#2519, F.S.S.
	10-20-71 APP'D. GTC

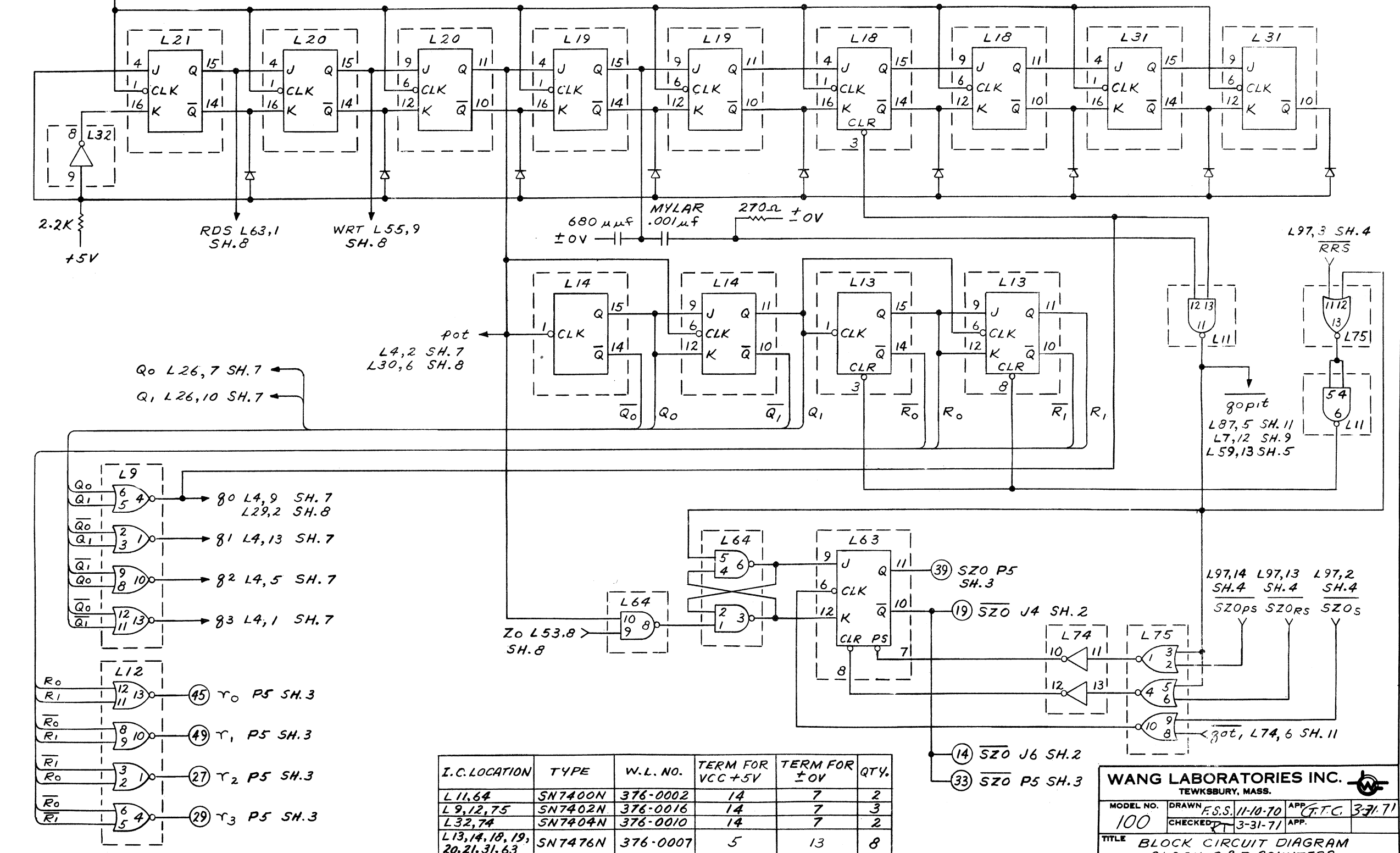
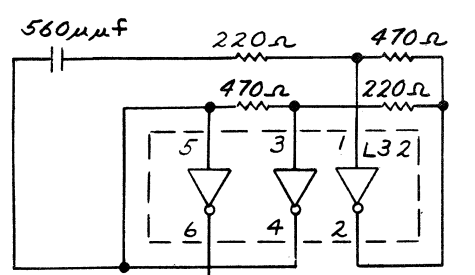

Q₀ L26,7 SH.7
Q₁ L26,10 SH.7

pot L4,2 SH.7
L30,6 SH.8

gopit L87,5 SH.11
L7,12 SH.9
L59,13 SH.5

L97,14 L97,13 L97,2
SH.4 SH.4 SH.4
SZOps SZORs SZOs

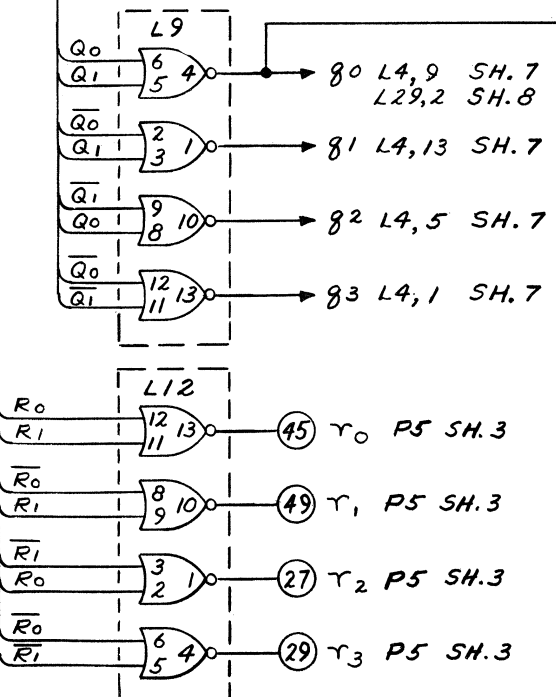

I.C. LOCATION	TYPE	W.L. NO.	TERM FOR VCC +5V	TERM FOR ±0V	QTY.
L11,64	SN7400N	376-0002	14	7	2
L9,12,75	SN7402N	376-0016	14	7	3
L32,74	SN7404N	376-0010	14	7	2
L13,14,18,19,20,21,31,63	SN7476N	376-0007	5	13	8

WANG LABORATORIES INC.
TEWKSBURY, MASS.

MODEL NO.	DRAWN	APP'D.
100	F.S.S. 11-10-70	G.T.C. 3-31-71
CHECKED	APP'D.	
	3-31-71	

TITLE: BLOCK CIRCUIT DIAGRAM
CLOCK Q & R FLIP COUNTERS
Z = ZERO FLIP-FLOP

W.O. NO.	DWG. NO.	REV.
	C6095-1 SH10OF12	4

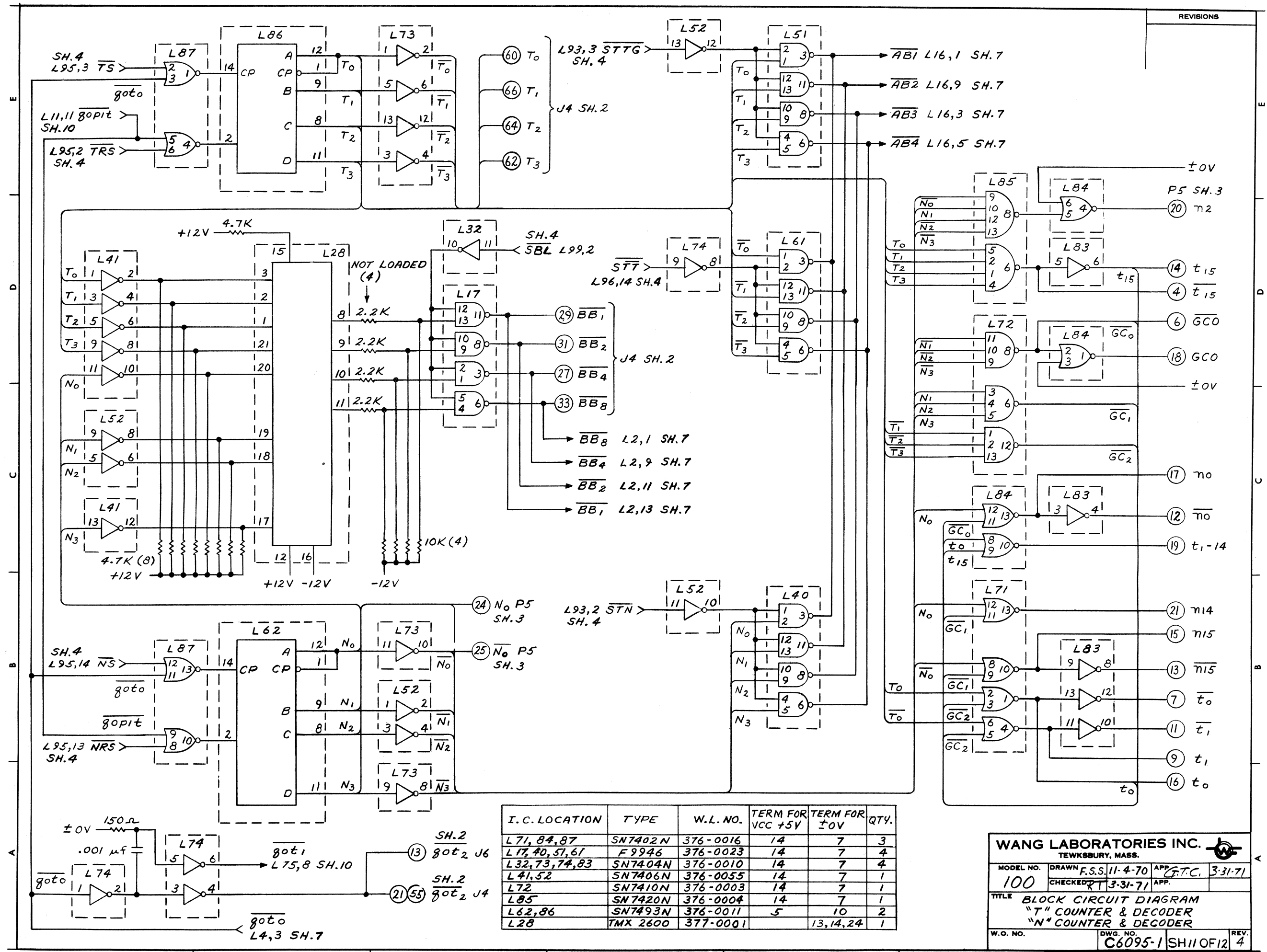

I.C. LOCATION	TYPE	W.L. NO.	TERM FOR VCC +5V	TERM FOR ±0V	QTY.
L71, 84, 87	SN7402N	376-0016	14	7	3
L17, 40, 51, 61	F9946	376-0023	14	7	4
L32, 73, 74, 83	SN7404N	376-0010	14	7	4
L41, 52	SN7406N	376-0055	14	7	1
L72	SN7410N	376-0003	14	7	1
L85	SN7420N	376-0004	14	7	1
L62, 86	SN7493N	376-0011	5	10	2
L28	TMX 2600	377-0001		13, 14, 24	1

WANG LABORATORIES INC.
TEWKSBURY, MASS.

MODEL NO. 100
DRAWN F.S.S. 11-4-70
CHECKED BY T.T. 3-31-71

APP. J.T.C. 3-31-71

TITLE: BLOCK CIRCUIT DIAGRAM
"T" COUNTER & DECODER
"N" COUNTER & DECODER

W.O. NO. C6095-1 SH11 OF 12
REV. 4

REVISIONS
 REVISED: PER
 E.C. 2274 F.S.S.
 7-20-71 APP'D G.T.C.

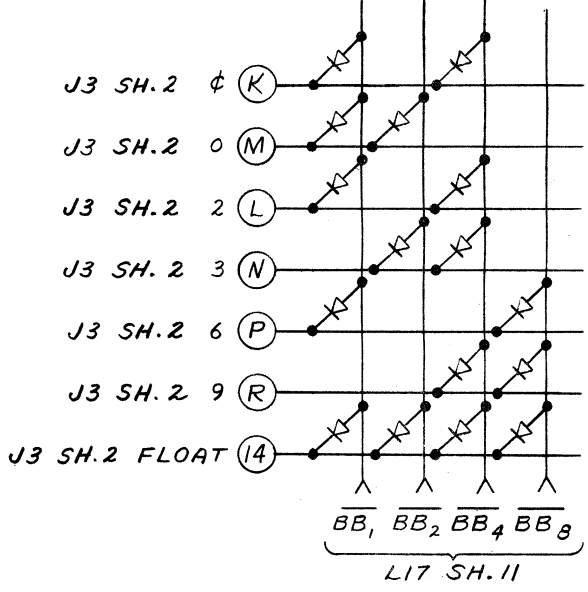
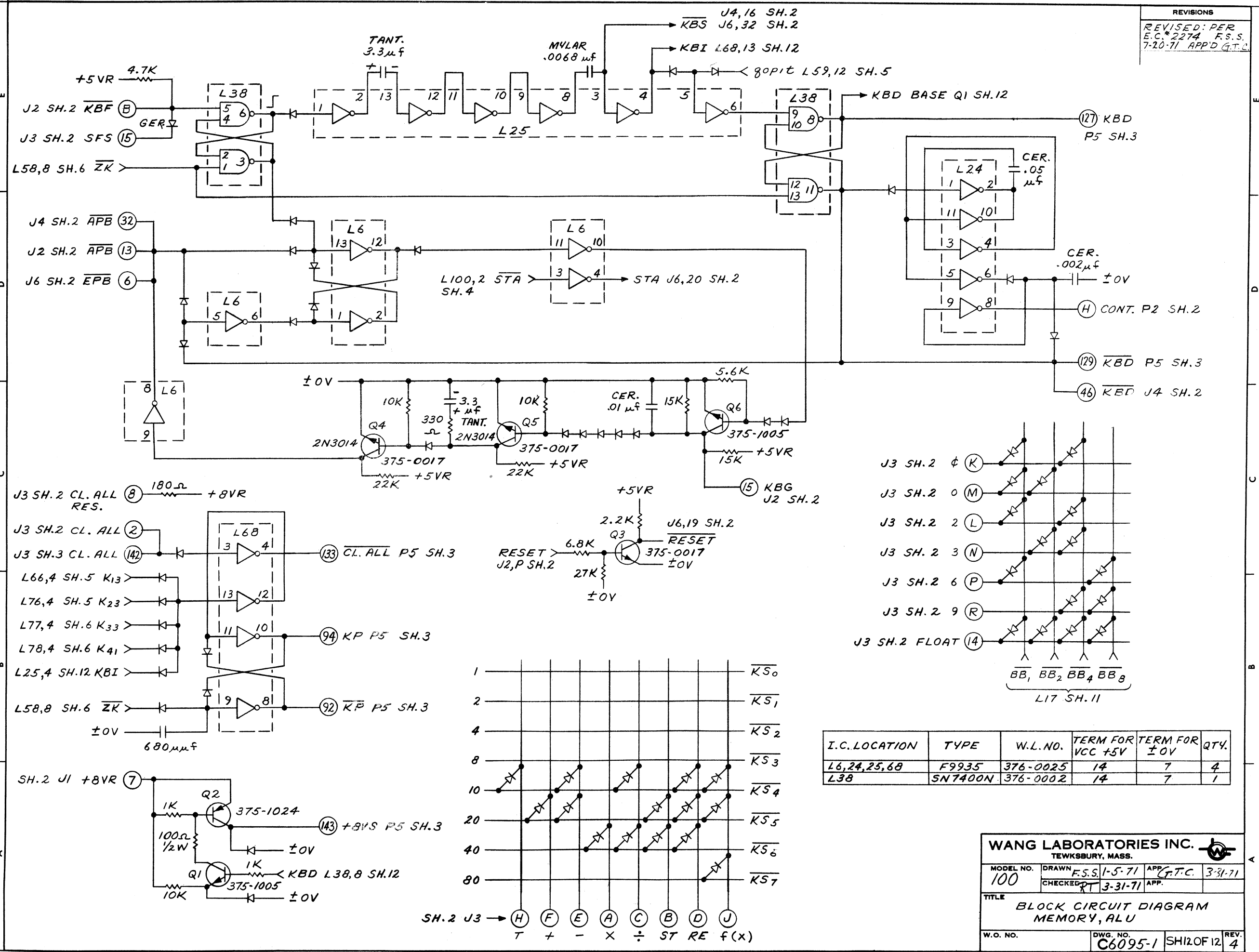

I.C. LOCATION	TYPE	W.L. NO.	TERM FOR VCC +5V	TERM FOR ±0V	QTY.
L6,24,25,68	F9935	376-0025	14	7	4
L38	SN7400N	376-0002	14	7	1

WANG LABORATORIES INC.
 TEWKSBURY, MASS.

MODEL NO. 100
 DRAWN F.S.S. 1-5-71
 CHECKED RT 3-31-71

APP. G.T.C. 3-31-71

TITLE: **BLOCK CIRCUIT DIAGRAM
 MEMORY, ALU**

W.O. NO. DWG. NO. C6095-1 SH12 OF 12 REV. 4

REVISIONS
 REVISED PER
 E.C. # 2109
 F.S.S. 4-29-71
 APPD RT

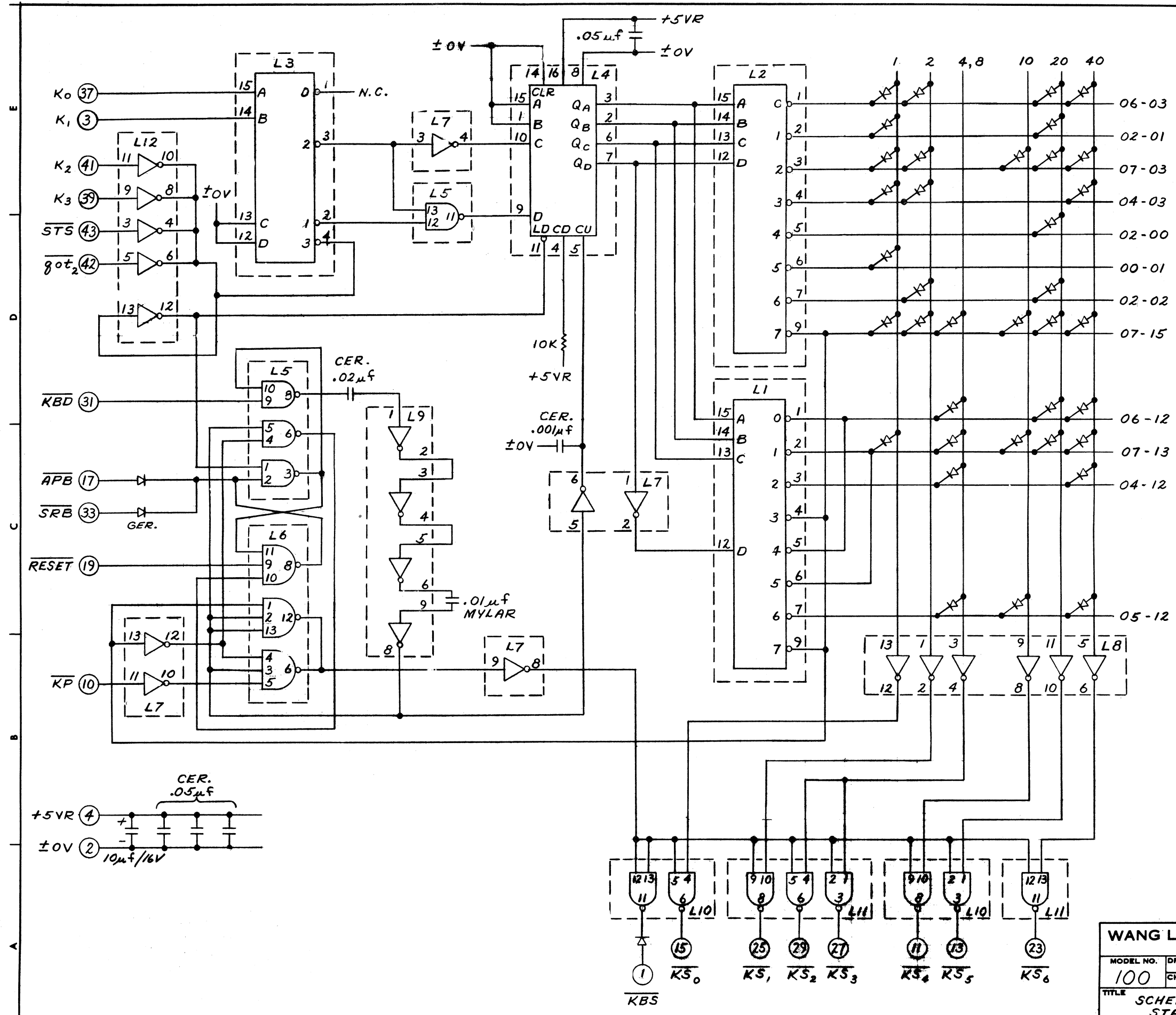

WANG LABORATORIES INC.
 TEWKSBURY, MASS.

MODEL NO.	DRAWN F.S.S. 2-2-71	APP. G.T.C. 3-31-71
100	CHECKED R 3-31-71	APP.
TITLE SCHEMATIC LOGIBLOC #6105-1 STATISTICAL SUB-ROUTINE		
W.O. NO.	DWG. NO. C6105-1 SM1 OF 2	REV. 2

REVISIONS
 REVISED: PER
 E.C. #2393 F.S.S
 9-9-71 APPD. GTC

6105 COMPONENT LAYOUT

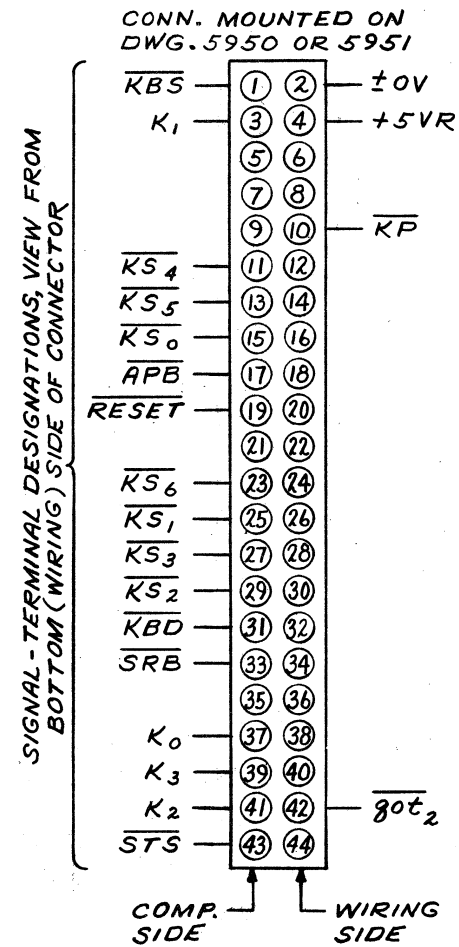
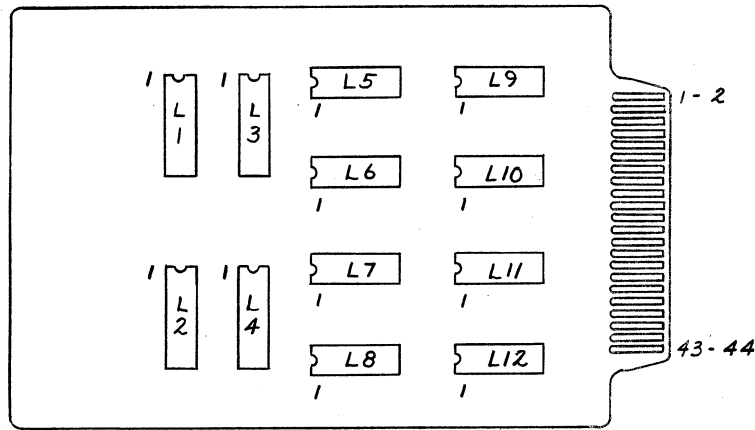

I.C. LOCATION	TYPE	W.L. NO.	TERM FOR VCC +5V	TERM FOR $\pm 0V$	QTY.
L5	SN7400N	376-0002	14	7	1
L1,2,3	SN74145	376-0069	16	8	3
L8,9	F9935	376-0025	14	7	2
L7,12	F9936	376-0026	14	7	2
L10,11	F9946	376-0023	14	7	2
L6	F9962	376-0034	14	7	1
L4	SN74193	376-0053	16	8	1

WANG LABORATORIES INC.
 TEWKSBURY, MASS.

MODEL NO.	DRAWN F.S.S. 2-3-71	APP. G.T.C. 3-31-71
100	CHECKED RT 3-31-71	APP.
TITLE SCHEMATIC LOGIBLOC #6105-1 STATISTICAL SUB-ROUTINE		
W.O. NO.	DWG. NO. C6105-1	REV. SH20F2 2

1-50190 ON 9MAG

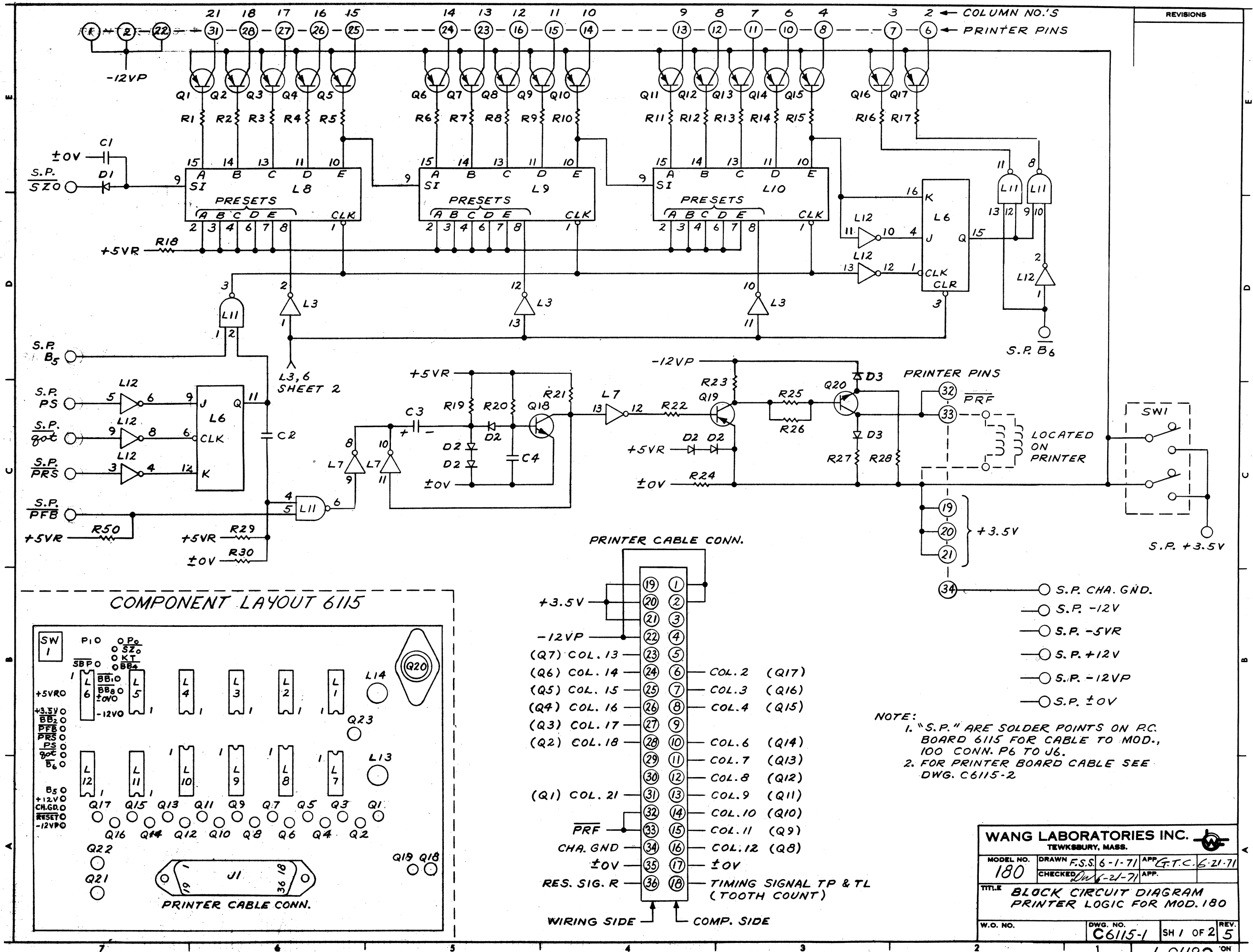

REVISED	REVISIONS

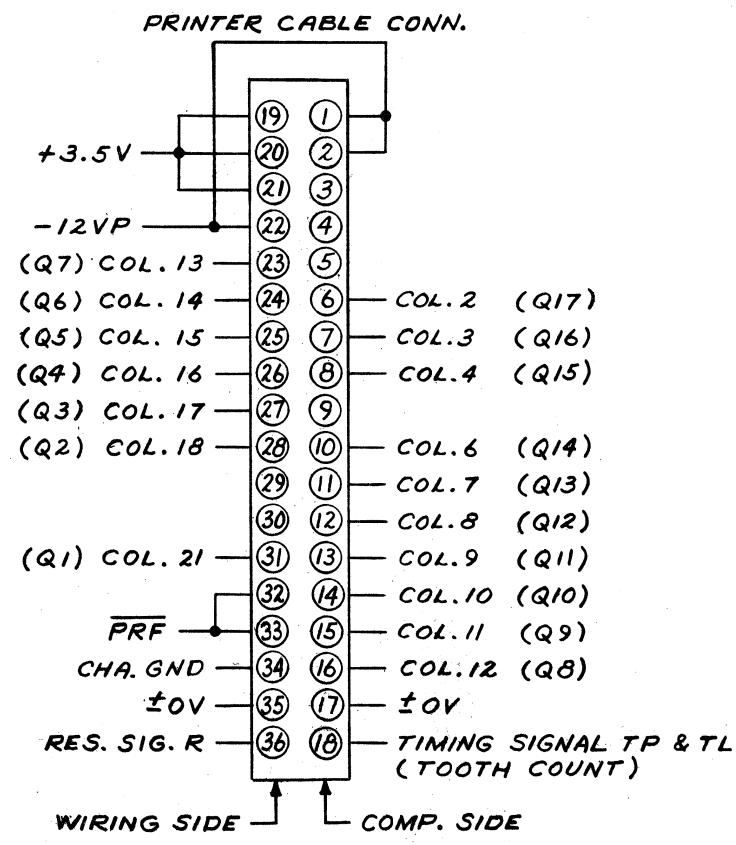
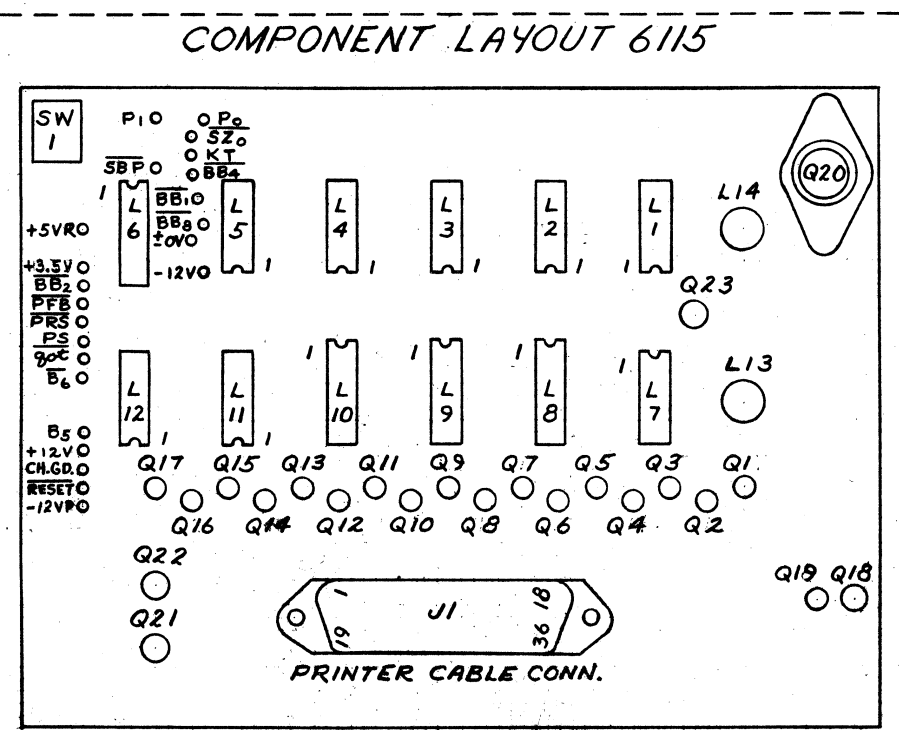

NOTE:
 1. "S.P." ARE SOLDER POINTS ON P.C. BOARD 6115 FOR CABLE TO MOD., 100 CONN. P6 TO J6.
 2. FOR PRINTER BOARD CABLE SEE DWG. C6115-2

WANG LABORATORIES INC.
 TEWKSBURY, MASS.

MODEL NO.	DRAWN	F.S.S.	6-1-71	APP.	G.T.C.	6-21-71
180	CHECKED	Duf	6-21-71	APP.		

TITLE: **BLOCK CIRCUIT DIAGRAM PRINTER LOGIC FOR MOD. 180**

W.O. NO.	DWG. NO.	SH	REV.
	C6115-1	1	5

1-9/19 ON 5MG

REVISIONS
REVISED: PER E.C. #2316, F.S.S. 8-4-71 APP'D GTC
REVISED: PER E.C. #2378, F.S.S. 8-28-71 APP'D GTC
REVISED: PER E.C. #2492, F.S.S. 10-9-71 APP'D GTC
REVISED: PER E.C. #2831, F.S.S. 3-20-72 APP'D SKH
REVISED: PER E.C. #3383, F.S.S. 11-20-72 APP'D JKH

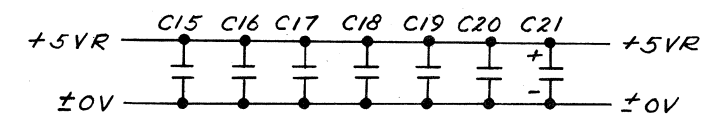
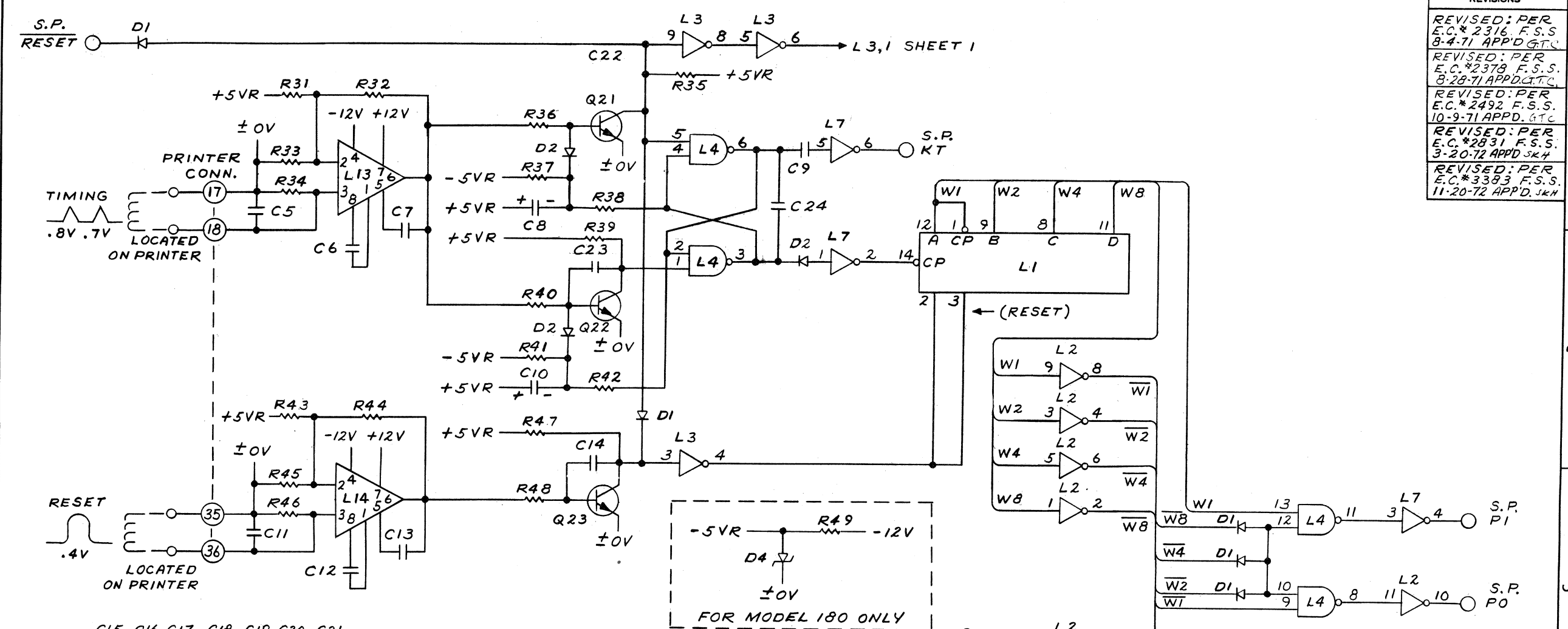

I.C. LOCATION	TYPE	W.L. NO.	TERM FOR ±0V	TERM FOR VCC +5VR	QTY.
L13,14	709C	376-0000			2
L4	SN7400N	376-0002	7	14	1
L5	SN7408N	376-0028	7	14	1
L2,3,12	SN7404N	376-0010	7	14	3
L6	SN7476N	376-0007	13	5	1
L1	SN7493N	376-0011	10	5	1
L8,9,10	SN7496N	376-0065	12	5	3
L7	F9935	376-0025	7	14	1
L11	F9946	376-0023	7	14	1

COMPONENT	SIZE, TYPE	W.L. NO.	QTY.
Q1,2,3,4,5,6,7,8,9,10,11,12,13,14,15,16,17,19	GT544	375-1017	18
Q18,21,22,23	SIL. CORE DR.	375-1005	4
Q20	40250	375-1022	1
SW1	P.B. SW	325-2215	1
U1	57-10360	350-2049	1

COMPONENT	SIZE, TYPE	W.L. NO.	QTY.
R1,2,3,4,5,6,7,8,9,10,11,12,13,14,15,16,17,24	470Ω 1/4W	330-2047	18
R49	470Ω 1/2W	331-2047	1
R18,34,46	4.7K 1/4W	330-3047	3
R19	4.7K 1/4W	330-4047	1
R20	2.2K 1/4W	330-4022	1
R21,28,30,37,41	2.2K 1/4W	330-3022	5
R22,23	1K 1/4W	330-3010	2
R25,26	220Ω 1/4W	330-2022	2
R27	3.3Ω 1/2W	331-0033	1
R29	2.7K 1/4W	330-3027	1
R31	680K 1/4W	330-5068	1
R32	220K 1/4W	330-5022	1
R33,45	6.8K 1/4W	330-3068	2
R35,36,39,40,47,48	12K 1/4W	330-4012	6
R44	470K 1/4W	330-5047	1
C21	15μF 15V	300-3007	1
C1,7,13	220μF	300-1220	3
C2	.0047μF 500V	300-1910	1
C3,8	2.2μF TANT.	300-4014	2
C4,5,11	.01μF 25V	300-1903	3
C6,12,24	.001μF 200V	300-1906	3
C9	.015μF 100V	300-2115	1
C10	5.6μF TANT.	300-4017	1
C14,23	.0056μF 200V	300-1915	2
C15,16,17,18,19,20	.05μF 12V	300-1900	6
D1	GERM.	380-0000	6
D2	SIL.	380-1001	8
D3	1N4719	380-3002	2
D4	1N4733A	380-2052	1

COMPONENT	SIZE, TYPE	W.L. NO.	QTY.
R38,42	820Ω 1/4W	330-2082	2
R43	1M 1/4W	330-6010	1
R50	10K 1/4W	330-4010	1

WANG LABORATORIES INC.
TEWKSBURY, MASS.

MODEL NO. 180
DRAWN F.S.S. 6-4-71
CHECKED J.W. 6/21/71

APPL. T.C. 6-21-71
APP.

TITLE: BLOCK CIRCUIT DIAGRAM
PRINTER LOGIC FOR MOD. 180

W.O. NO. DWG. NO. C6115-1 SH2 OF 2 REV. 5

REVISIONS
 REVISED: PER
 E.C.*2547 F.S.S.
 11-3-71 APP'D G.T.C.
 REVISED: PER
 E.C.*2578 F.S.S.
 11-29-71 APP'D J.A.

18 17 16 15 14 13 12 11 10 9 8 7 6 5 4 3 2 1
 36 35 34 33 32 31 30 29 28 27 26 25 24 23 22 21 20 19

P.C. BOARD S.P.	CONN. PIN NO.	WIRE NO.
F ₀	33	27
P ₁	34	28
SZ ₀	14	14
KT	35	29
BB ₄	21	21
SBP	31	26
BB ₁	23	23
BB ₈	10	10
+0V	5	5 & 6
-12V	36	30
+5VR	4	4 & 22
+3.5V	17	17
BB ₂	9	9
PFB	.2	2
PRS	15	15
PS	16	16
got	13	13
B ₆	7	7
B ₅	8	8
+12V	3	3
CHA. GND.	11	11 & 12
RESET	19	19
-12VP	18	18

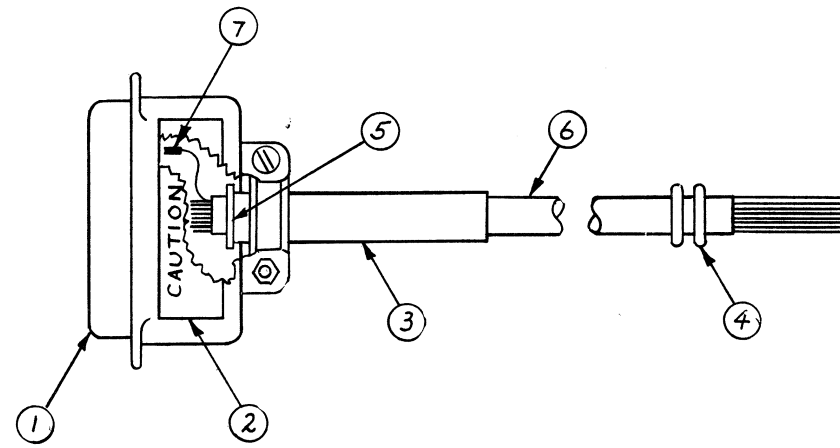
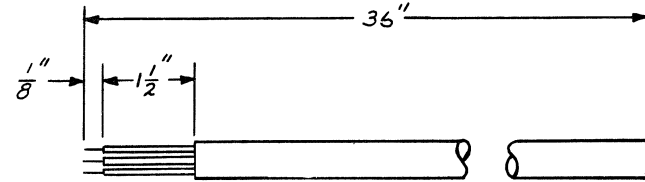

IDENT	QTY	NAME	WANG LAB NO.	DESCRIPTION
1	1	CONNECTOR	350-2025	AMPH. 57-30360
2	1	LABEL	615-1101	WARNING LABEL
3	1	SLEEVE	605-0106	NEOP. SLEEVE 3" LG.
4	1	GROMMET	654-1212	5/16 I.D. FOR 7/16 HOLE
5	1	STRAIN RELIEF	654-1208	WALKER *6
6	1	CABLE	420-0013	30 COND. *26 GAUGE
7	A/R	SOLDER	660-0202	63-37

NOTE:
 1. SEE DWG. C6115-1 SH. 1 OF 2 FOR S.P. DESIGNATIONS.

WANG LABORATORIES INC. TEWKSBURY, MASS.

MODEL NO.	DRAWN	F.S.S.	6-10-71	APP	G.T.C.	6-21-71
180	CHECKED	J.W.	6-21-71	APP.		
TITLE 6115/ PRINTER INTERCONNECTING CABLE						
W.O. NO.	DWG. NO.	REV.				
220-0060	C 6115-2	2				

2-91190 ON DWG